



# Overview of SARNET Activities in the Source Term Area

European Review Meeting on Severe Accident Research  
(ERMSAR-2005)

Aix-en-Provence, France, 14-16 November 2005

*T. Haste<sup>1</sup>, P. Giordano<sup>2</sup>, L. Herranz<sup>3</sup>*

*<sup>1</sup>PSI Villigen, Switzerland, <sup>2</sup>IRSN Cadarache, France, <sup>3</sup>CIEMAT Madrid, Spain*

## OVERVIEW

- The Source Term area is one of the three topical areas in SARNET, along with Containment and Corium
- The area is divided into three main parts:
  - fission product release and transport (WP14 - FPRT)
  - aerosol behaviour, impact on the source term (WP15 - AEROB)
  - containment chemistry, impact on source term (WP16 - CONTCHEM)
- The FPRT area is itself split into two parts:
  - oxidising environment influence on source term (WP14.1 – OXIDEN)
  - RCS high temperature chemistry impact on the source term (WP14.2 – HITEMP)
- This presentation summarises the detailed objectives, the main actors and facilities involved, and the results to date

## SOURCE TERM AIMS

- WP14.1 HITEMP: effect of air ingress - under such conditions, the fuel and its fission products (FPs) may oxidise. Some (especially the very radio-toxic ruthenium) may form highly volatile oxide species which may be released to the environment;
- WP14.2 OXIDEN: iodine volatility in the Reactor Coolant System (RCS) - the impact of high temperature on FP behaviour is investigated to improve the predictability of iodine species exiting the RCS; the effect of silver-indium-cadmium release on the speciation is also considered;
- WP15 AEROB: aerosol behaviour – quantification of the source term following steam generator tube rupture, which leads to containment by-pass; aerosol leakages through containment concrete wall cracks, interaction of deposited aerosols with the RCS substrate and revaporisation phenomena are also studied;
- WP16 CONTCHEM: iodine behaviour in-containment - to improve the predictability of the various chemical and physical processes which control the iodine behaviour in both the gas and water phases

## SOURCE TERM ORGANISATION

- The basic methodology is the same as in the other topical areas
  - review and selection of available experiments, synthesis of analysis and interpretation from these experiments, synthesis of and proposals of models for ASTEC
  - in some cases, plant calculations are used to help define conditions for experiments
  - cooperation has been effectively established through technical circles
  - exchanges with WP7 (Research Priorities) on raising new issues and discharge of existing ones
  - dissemination mainly via conference papers for now
  - liaison with international programmes and organisations as appropriate, also links in SARNET especially with WP9 (Corium area)
  - participation in the Mobility programme
    - one secondment completed, 4 months, CIEMAT to PSI; aerosol physics
    - one in progress, 9 months, INR to IRSN; air ingress matters

1- FP release under highly oxidizing conditions (air ingress) (WP14-1) :

Air ingress into the reactor pressure vessel may be induced by buoyancy forces after RPV failure due to penetration by corium

Interrogations (implications for Source Term) :

- in a very oxidising environment, low-volatile fission products would be released, especially ruthenium, possibly increasing the radiological hazard :

**rate and kinetics of ruthenium release ?**

- in a very oxidising environment, previously deposited fission products would partly be volatilised, possibly inducing a delayed release to the containment :

**revaporisation from RCS deposits (I<sub>2</sub>, Ru,..)?**

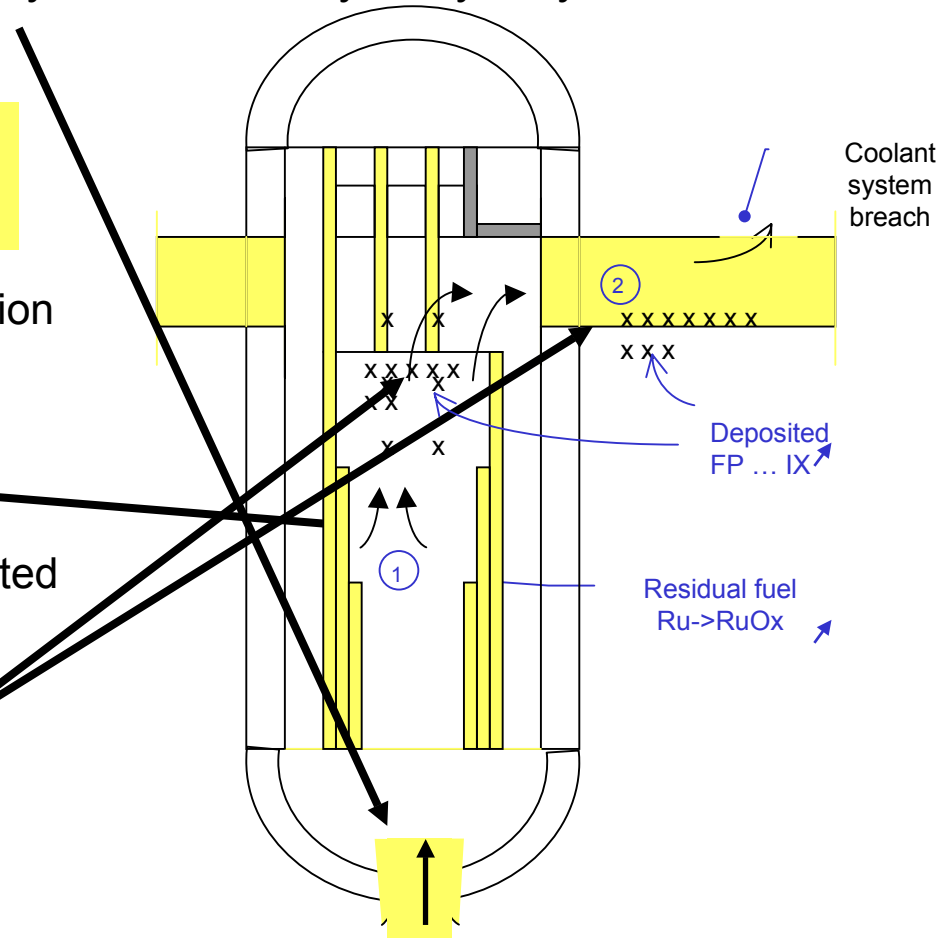

## 2- Transport : High temperature gas phase - chemistry in RCS (WP14-2) :

vapour phase phenomena occur during species transport in circuit

### Interrogations (implications for Source Term) :

- depending on conditions, a fraction of iodine species may exit the RCS in volatile form : **iodine speciation in RCS ?**
- Silver-Indium-Cadmium interact with FPs (similar release time windows) : **rate and kinetics of SIC release**

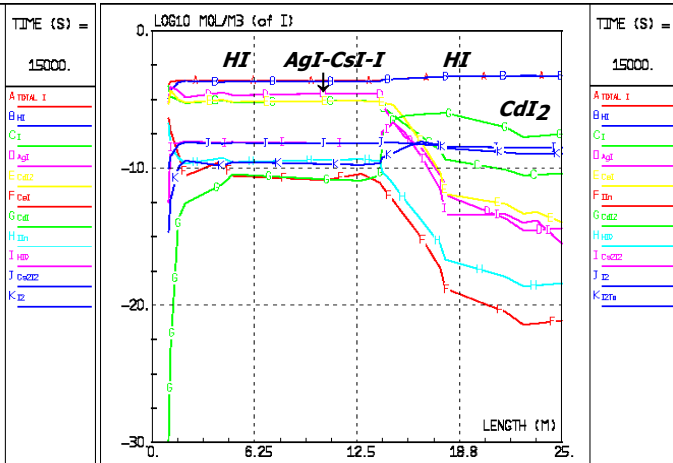
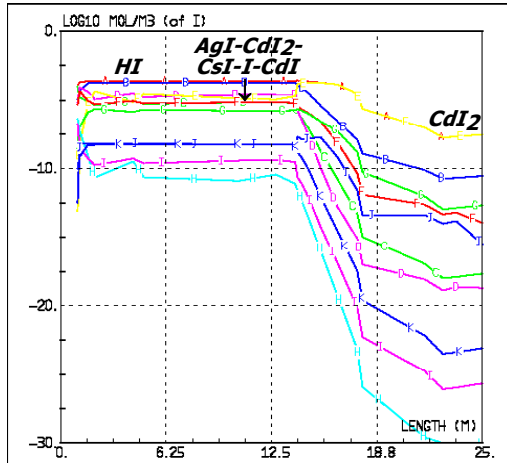
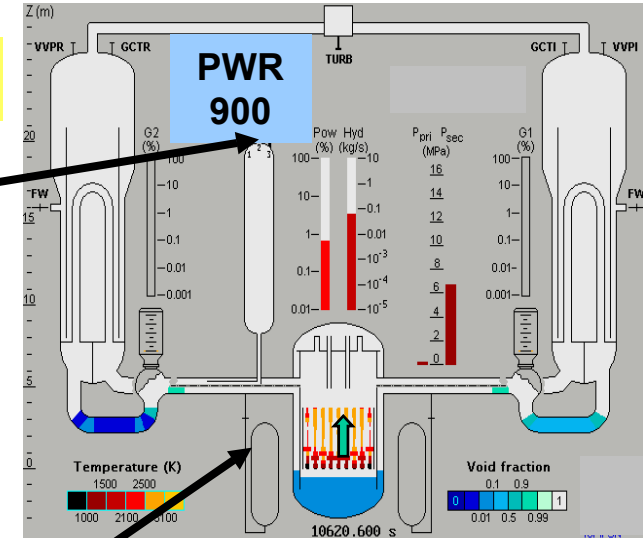

I (gas\_phase) : AXIAL MOLAR PROFILE FROM SPECIES

I (gas\_phase) : AXIAL MOLAR PROFILE PER SPECIES no-Cd phase

### 3- Aerosol behaviour impact on Source Term (WP15):

#### Interrogations (implications for Source Term) :

In severe accident conditions, the containment building may be weakened and leakages may appear. Suspended aerosols may escape the reactor building through wall cracks : retention in cracks has a direct impact on aerosol ST evaluation.

**quantification of FP retention in wall cracks?**

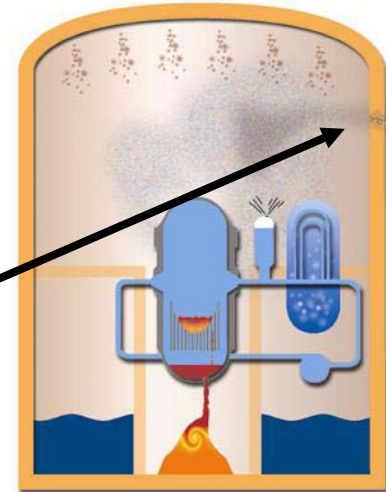

In the case of a Steam Generator Tube Rupture (SGTR), a containment bypass may occur : **quantification of aerosol retention in SG** would reduce the existing large uncertainties on ST evaluation in such accident scenarios.

During an accident, some previously-condensed FP vapours in RCS may be revaporised : heating of deposits, interaction with substrate, chemical reaction in condensed phase or with gas,... This delayed release would potentially increase the ST : **remobilization of deposits in the RCS?**

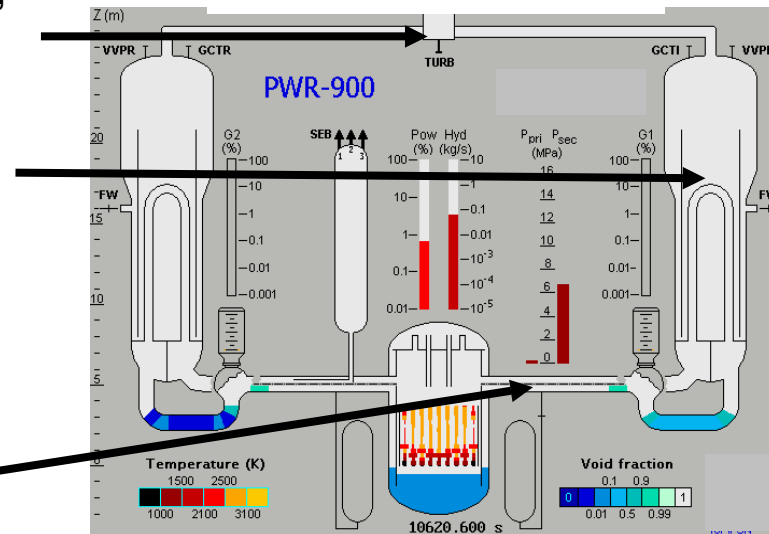

#### 4- Containment chemistry (WP16):

numerous chemical processes occur in containment

#### Interrogations :

**Organic iodides**, RI, could dominate volatile iodine fraction in the long term (conclusion from Phébus FP, TMI-2) : these are highly volatile species, barely trapped by actual filters; evaluation of their prevalence has a direct impact on Source Term evaluation.

**Adsorption/desorption of iodine** on/from surfaces has a significant impact on ST as adsorbed  $I_2$  influences the  $I_2$  inventory in the gas phase (e.g. conversion rate to RI).

Depending on conditions, **liquid-gas mass transfer phenomena may be enhanced**, increasing the gas-phase iodine content.

Low **radiolytic production of gaseous iodine** from the sump due to the presence of Ag may significantly reduce the iodine Source Term.

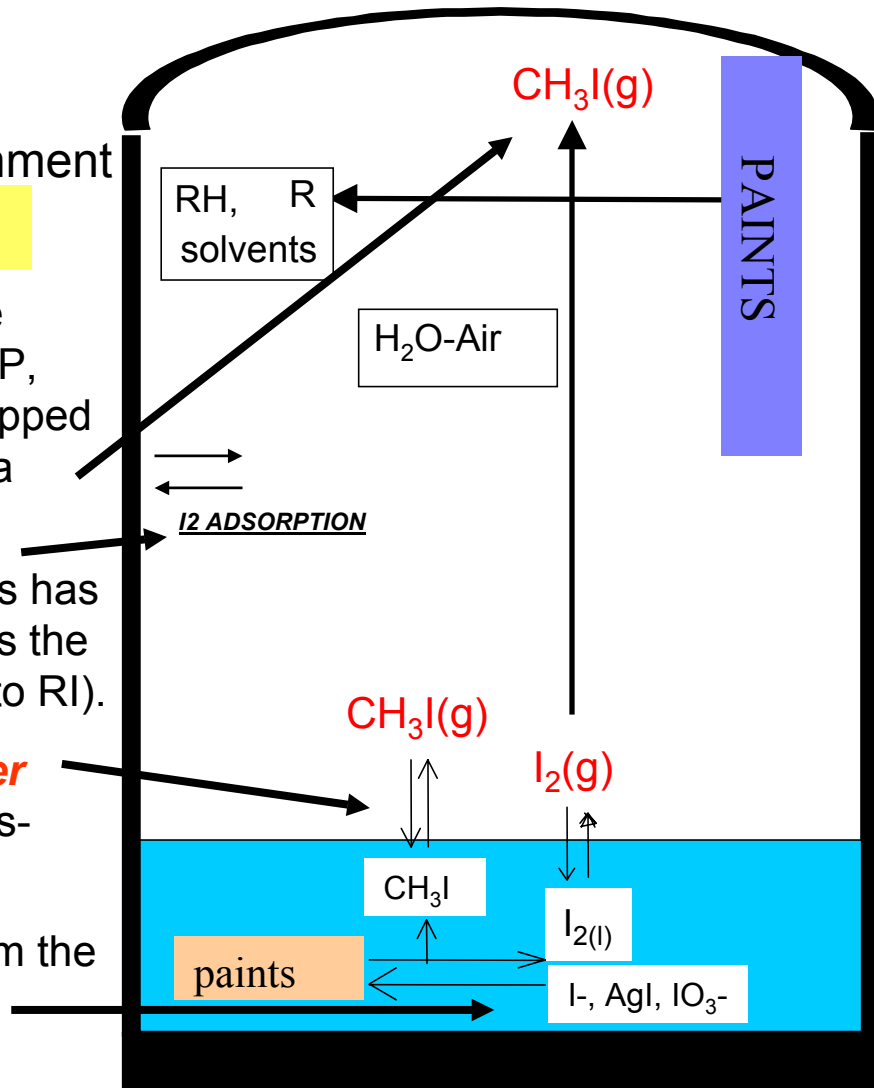

1- FP release under highly oxidizing conditions (WP14-1) :

**Experimental means :**

RUSET (AEKI), Ru speciation (VTT)

VERDON (CEA) , analytical tests (UCL)

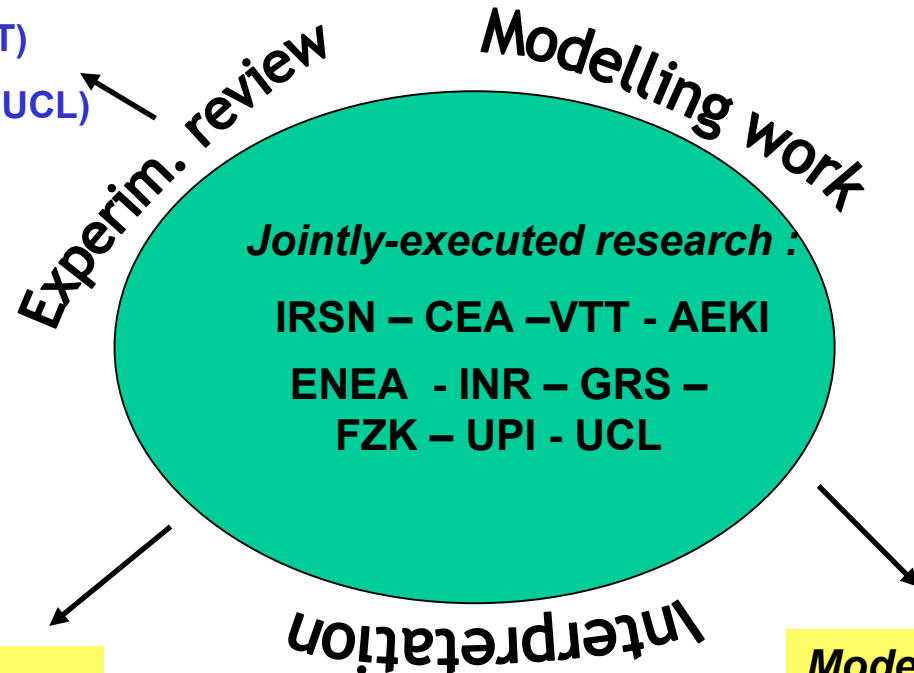
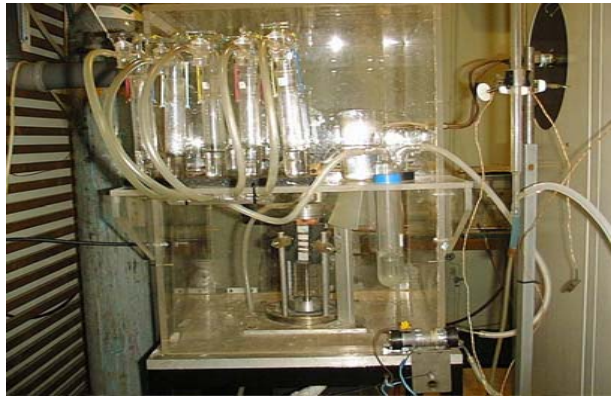

**Reactor scenario calculations :**

ASTEC, ICARE/CATHARE (IRSN)

SATURNE, MAAP (EDF)

SCDAP/RELAP5, ICARE/CATHARE (INR)

**Model proposals :**

**UO<sub>2</sub> oxidation kinetics**

**Ru release kinetics**

2- Transport : High temperature gas phase chemistry in RCS (WP14-2) :

**Experimental means :**

- PHEBUS FP FPT2 (IRSN)
- CHIP (IRSN)
- EMAIC (CEA), VERCORS HT (CEA)

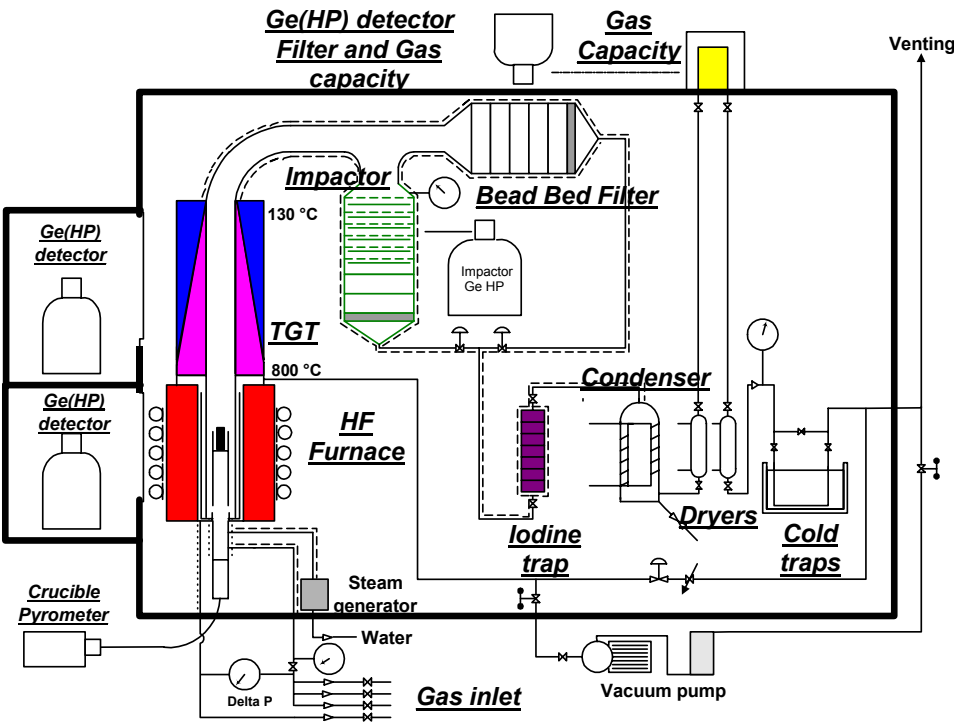
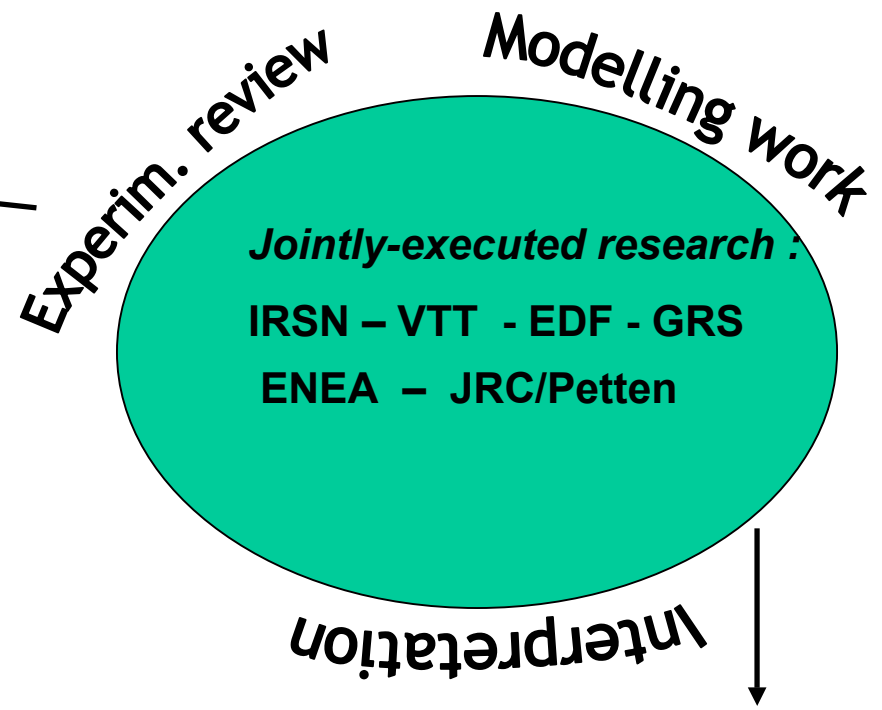

**Model proposals :**

- SIC release kinetics
- Iodine speciation in RCS

### 3- Aerosol behaviour impact on Source Term (WP15):

**Experimental means :** PHEBUS FP (IRSN), REVAP (JRC-TUI), RADSOL (UCL), SGTR (CIEMAT)  
 ARTIST (PSI), PSAERO/HORIZON (FORTUM)

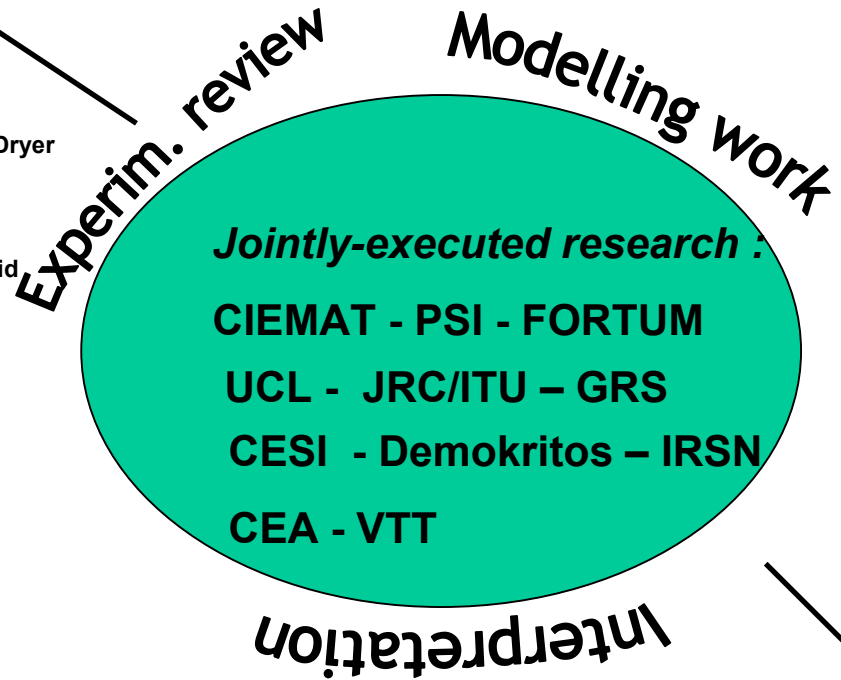
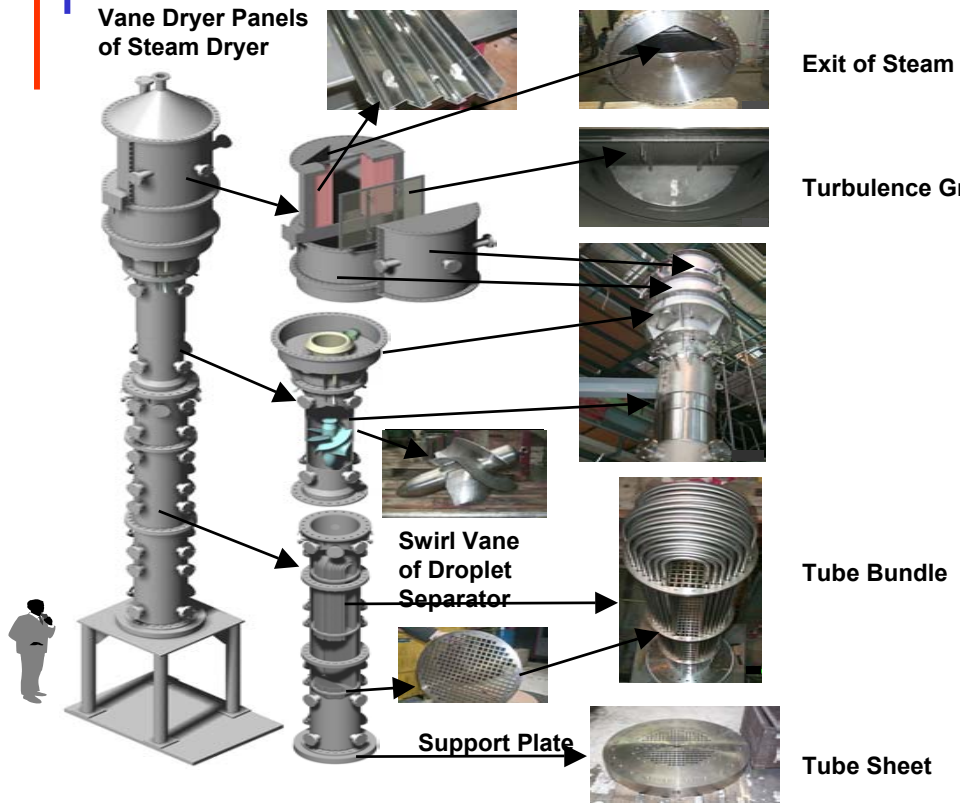

**Model proposals :**

- Aerosol retention in cracks**
- Aerosol retention in SG**
- Deposit remobilization**

#### 4- Containment chemistry (WP16) :

**Experimental means :**

- Chalmers tests (Univ.), CAIMAN (CEA)
- PARIS (FRA/ANP), SISYPHE (IRSN)
- PHEBUS FP (IRSN)
- EPICUR (IRSN)



**Iodine data book :**

AEAT

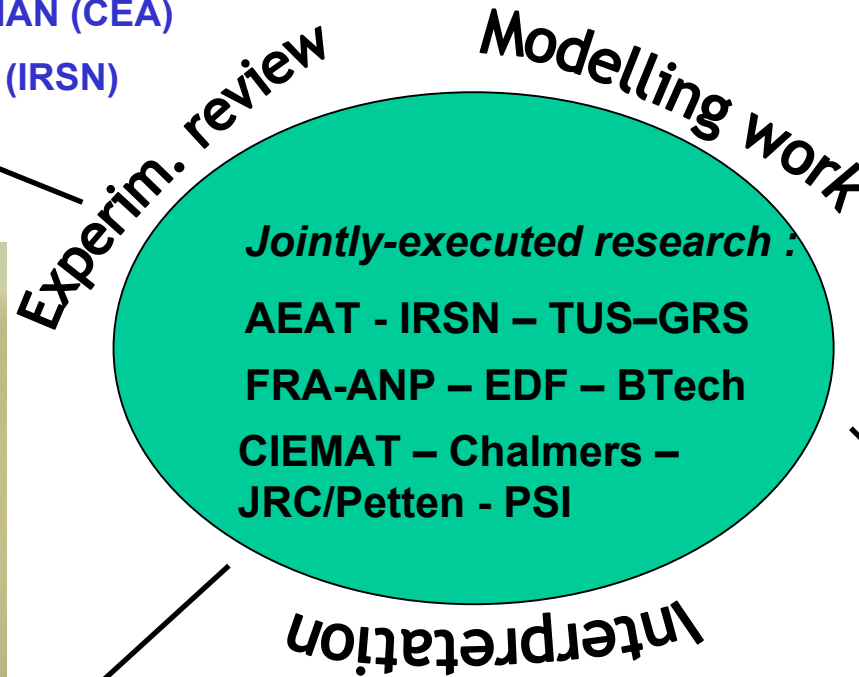

**Model proposals :**

- Adsorption/desorption
- Liq-gas mass transfer
- RI formation/destruction
- Ag oxidation

## PRELIMINARY RESULTS - OXIDEN

- Ruthenium release occurs in oxide form after an incubation period during which full oxidation of fuel and cladding occurs (RUSSET tests)
- Oxide forms can stay volatile enough at lower temperatures to be transported to the reactor containment (RUSSET and VTT tests)
- Further data are required
  - RUSSET (Ru release and transport); VTT (Ru speciation)
  - VERDON (FP release from irradiated fuel); MERARG trial experiment (FP release in air)
- Conditions in future experiments are being determined with the aid of reactor calculations, for example:
  - 3D simulations, MAAP/SATURNE: upper limit of air ingress following lower head failure due to core melt is 20 mol/s
  - ICARE/CATHARE: temperatures up to 2000K could persist in the core region after ex-vessel core slump, and core degradation could restart after air ingress

## PRELIMINARY RESULTS – HITEMP

- Iodine transport through the RCS is dependent on conditions (PHEBUS-FP, VERCORS and EMAIC experiments)
- Under reducing conditions and in the absence of Ag/In/Cd, it enters the containment as CsI and/or RbI; however, under oxidising conditions metal iodides other than CsI can be formed (even HI can be formed)
  - at hot-leg break temperatures, HI and metal iodides would all be significant species whatever the steam-hydrogen mixture or absorber content
  - at cold-leg break temperatures, the ratio of HI to metal iodides increases for steam-rich mixtures if control-metal release is low. In other words, more hydrogen and more control rod metals appear to lead to lower-volatility iodine species, viz. metal iodides
- These statements need to be confirmed
- Future CHIP tests will provide useful data for a full understanding
  - kinetic and thermodynamic data on iodine transport to RCS breaks
  - collaboration established between IRSN and VTT on design studies
- The experimental database on SIC release is being reviewed (EMAIC, Phebus, Winfrith tests etc.) and current modelling studied (MAAP, ATHLET-CD) as steps towards improved treatments

## PRELIMINARY RESULTS - AEROB

- The secondary side of a steam generator can provide some decontamination, even under dry conditions (ARTIST tests, SGTR tests)
- Such decontamination is greatly enhanced if water is present in the secondary side of a steam generator
- These statements need quantification and deep understanding to develop an accurate and reliable model. Phenomena like resuspension seem to play a key role in the scenario
- Aerosol can be effectively retained when moving along cracks in the containment wall, particularly in the presence of steam (SIMIBE tests). More data are needed to support the theoretical developments underway
- Caesium deposited in the primary circuit can revaporise to a very high extent from 550 °C (REVAP tests on Phebus FP samples). Further tests needed to achieve a correlation of results

## PRELIMINARY RESULTS - CONTCHEM

- MAAP 4.0, IMPAIR3 and IODE 5.2 models comparison in the issues of interest, as well as preliminary comparisons to experimental data (PHEBUS-FP), have highlighted the need to develop more realistic and accurate models. In addition, analytical data are requested.
- Experimental programmes presently ongoing are SISYPHE, EPICUR, PARIS. Individual interpretation work has already started and progress is being made towards a joint discussion among partners in issues like mass transfer.
- An Iodine Data Book is being written to summarise current knowledge

## DISSEMINATION

- Three papers included in Nuclear Energy in New Europe conference, Bled, Slovenia, 5th-8th September 2005
  - SARNET Severe Accident Research Network: Key Issues in the Area of Source Term by the ST management team plus coordinator, presented
  - Investigations on Ruthenium Transport in Highly Oxidising Conditions by A Auvinen et al., presented
  - Investigations on Aerosol Transport in Containment Cracks, by F Parozzi et al., poster
- Poster and paper at the Spanish Nuclear Society Meeting, Logroño, Spain, 19th-21st October 2005
  - Source Term Research within the European Severe Accident Research Network (SARNET) by the Source Term Management Team
- Seminar at Newcastle University, UK, 15th December 2005
  - SARNET: Integrating Severe Accident Safety Research in Europe, by the Source Term Management Team

## CONCLUDING REMARKS

- The Source Term area has made a successful start, with substantial technical progress being made over a range of planned activities
- Good cooperation has been established amongst many partners, covering design of experiments, interpretation of results, and development of new models, e.g.
  - VTT, AEKI and IRSN on ruthenium release and transport
  - IRSN and VTT on design of the CHIP facility
  - IRSN, CEA, Demokritos and CESI on aerosol retention in cracks
  - more specific clustering on specific iodine chemistry issues, for example on mass transfer data and modelling
- Secondments have been instigated under the Mobility programme
- Cooperation has also been instigated with other programmes such as those of OECD/CSNI and ISTC
- Extension and maintenance of these activities in a sustainable way is foreseen in the coming years

*The authors thank the many technical contributors within SARNET organisations, too numerous to name, and the European Commission for funding SARNET, in the 6th Framework Programme area “Nuclear Fission: Safety of Existing Nuclear Installations”, under contract number FI6O-CT-2004-509065.*