



Research Needs in the Domain of Severe Accidents

Klaus Trambauer, GRS

Gesellschaft fuer Anlagen- und Reaktorsicherheit, Garching (DE)

European Review Meeting on Severe Accident Research

Aix-en-Provence, 14 -16 November 2005

Contents

- Objectives and Work Scope of Work Package 7 (SARP)
- EURSAFE Methodology and main Results
- Review of Work
- Strategy developed for updating the Priority List
- Acknowledgement

Objectives of Work Package on Severe Accident Research Priorities (SARP)

- Reassess the research priorities in the domain of SA
- Provide the GB with guidelines for joint research activities
- Correctly address the safety significance and risk potential
- Make use of
 - EURSAFE results
 - Application and qualification of ASTEC
 - Results of Level 2 PSA
 - Work progress in the topics Corium, Containment, Source Term

Work scope of SARP

- Agree on methodology
- Review EURSAFE issues not appropriately covered by SARNET
- Reassess the issue ranking
- Review potential experimental and theoretical programmes to address these issues
- Make recommendations for research and development (R&D) programme revision

SARP Organisation reflecting EURSAFE Structure

- Team with 12 members from
 - Universities:
 - ★ Kungl Tekniska Högskolan (KTH)
 - ★ Technical University of Sofia (TUS)
 - Regulatory Bodies and Technical Support Organizations (TSOs)
 - ★ Gesellschaft für Anlagen- und Reaktorsicherheit mbH (GRS)
 - ★ Institut de Radioprotection et de Sûreté Nucléaire (IRSN)
 - National Laboratories
 - ★ Commissariat à l'Energie Atomique (CEA)
 - ★ Forschungszentrum Karlsruhe (FZK)
 - ★ Technical Research Centre of Finland (VTT)
 - Industrial Organizations
 - ★ Electricité de France (EDF)

EURSAFE

European expert network for the reduction of uncertainties in severe accident safety issues

- Objectives
 - Establish a large consensus on the severe accident issues where large uncertainties still subsist
 - Propose a structure to address these uncertainties by appropriate R&D programmes making the best use of European resources
 - Issues incorporated
 - ★ Existing plants: PWR, BWR, VVER
 - ★ Lifetime extension, higher burn-up, MOX fuels
 - ★ Safety and efficiency of future systems
- 20 partners from 10 countries representing regulatory bodies, governmental institutions, universities, nuclear industry, utilities

PIRT: Phenomena Identification and Ranking Table

- **First step: Phenomena identification** for 5 domains (~1000)
 - In-vessel processes (160)
 - Ex-vessel processes (150)
 - Dynamic loading of RCS and containment (460)
 - Long term loading of containment (120)
 - Fission product and aerosol behaviour (130)

- **Classification and description of**
 - Physical situation
 - Issue
 - Reference number and identification of phenomenon
 - Brief description of phenomenon and specific features

Phenomena identification

Physical Situation	Issue	Ref. N.	Phenomenon	Phenomena Description	<i>others specific Features</i>
In-Vessel		1,0,000			
Corium Behaviour in Bottom Head		1,3,000			
Corium relocation to lower head	Initial conditions	1,3,011	Characteristics of corium arrival in lower plenum	The characteristics of corium arrival into the lower head are the chronology of successive slumps, the temperatures, masses and composition of corium flows, etc..	The timing and mode of the corium relocation process will modify the further behaviour of corium in the lower head. It will also affect the risk of steam explosion.
Fission Products		5,0,000			
Transport in Primary and Secondary System		5,2,000			
Aerosol phenomena	Resuspension	5,2,042	Re-volatilisation	Vaporisation of a deposited species, due to changes in temperature (including the effect of decay heat), vapour concentration or gas composition	

Voting for safety importance

- Relevance of the phenomena of 5 domains for 3 essentials
 - Integrity of reactor coolant system
 - Integrity of containment
 - Potential for release into environment (Source term)
- Rationale for voting: Vote level as function of
 - Probability: low, medium, high
 - Consequences: low, medium, high
- Importance Ratio
 - High: $IR \geq 2.33$
 - Low: $IR \leq 1.66$

$$IR = \frac{n_1 + 2n_2 + 3n_3}{n_1 + n_2 + n_3}$$

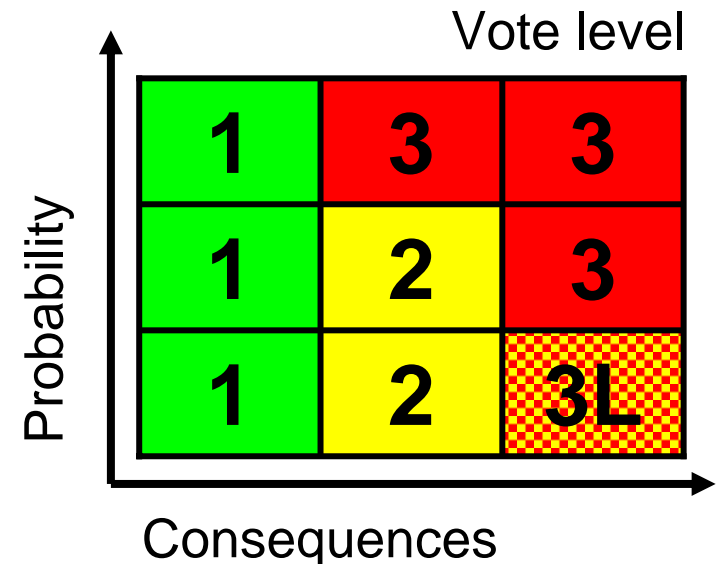

Rationale for voting on phenomena knowledge

- Voting restricted to 239 phenomena with
 - High importance ratio ($IR \geq 2.33$)
 - Bi-modal distribution of votes ($n_3 \sim n_1$ and $n_2 < \min(n_1, n_3)$)
 - Number of votes > 5 (out of 20 votes maximum)
- Ranking rationale: **Vote level**
 - **3:** The phenomenon/aspect is only partly understood. The models are rudimentary. The model verification is insufficient due to a significant lack of experimental data.
Needs significant R&D effort.
 - **2:** The phenomenon / aspect is on the whole understood, uncertainties remain for unexplored parameter ranges or extrapolation to reactor scale. The main processes are described by adequate models but the verification is not complete due to a limited understanding and to limited number of data.
 - **1:** The phenomenon/aspect is well understood. The processes are adequately modelled and well verified in general on an extended experimental basis.
Needs little or no R&D

PIRT implication

- Further evaluation restricted to 106 phenomena with high importance ratio **and** significant lack of knowledge (57 with first priority, 49 with 2nd)
- The PIRT implication included
 - Defining R&D needs in terms of objectives and priorities
 - Identifying required R&D tasks in terms of experimental programmes & codes
 - Reviewing the European facilities and codes which could be used for these tasks, taking into account the existing and planned programmes
- Select objectives of needed research with timely succession
 - **A:** perform experimental work to produce the missing information
 - **B:** perform analytical work to integrate the existing data in best estimate codes
 - **C:** develop a conservative approach
 - **D:** perform R&D work for the development of new AM procedures
- Integrate individual phenomena to items with same R&D orientation

PIRT implication table (extract for EURSAFE Research Item “ERI” 5.3)

Physical Situation	Issue	Phenomenon	Phenomena Description <i>others Specific Features</i>	Ref. N.	Item n. R.	Objectives of Needed Research	Description of Experimental Program or <i>Computer Code</i>
Aerosol phenomena	Resuspension	Re-volatilisation	Vaporisation of a deposited species, due to changes in temperature (including the effect of decay heat), vapour concentration or gas composition as well as abrupt pressure changes	5,2,042	5,3	A1 Integral tests with representative real materials A2 analytical experiments with simulants and/or samples from integral experiments. B3 improvement of existing codes see also 5,1,026, 5,1,050	PHEBUS 2K planned – air ingress and quench tests IMPAIR, SOPHAEROS
Retention in complex structures	Retention in complex structures	Secondary side of steam generator	Aerosol retention by various mechanisms in the secondary side of a steam generator in case of steam generator tube rupture and possible containment bypass. No prototypical data exists under realistic boundary conditions and obtained using the real components. Available models for retention as a result of obstacles cannot be used under steam generator secondary side conditions and geometry.	5,2,050	5,3	B1: analyses of reactor conditions A2: Integral and separate effect test B3: Model development and implementation based on SGTR and ARTIST data B4: Achieve realistic estimations of the source term	ATHLET-CD, ICARE/CATHARE ARTIST (PSI) program SOPHAEROS
Aerosol behaviour in containment	Retention in complex structure	Retention in containment leakage flow paths	Aerosol retention as they pass through various containment leakages (wall cracks, equipment hatch) Impact of water condensation is not well known, as tortuosities in cracks	5,4,060	5,3	B1: evaluate existing data (MAEVA) A2: Small scale exp. to estimate degree of aerosol leakage see 3,5,044	Exp. with well-defined cracks in representative concrete and standard aerosol sources and with on-line detection (AEA and DRAGON-PSI)
Transfer out of containment	Transfer by leaks	Retention in leakage paths	Fractions of molecular and Organic iodine retained in the leakage paths of the containment	5,5,080	5,3	C1: conservative approach, especially. for organic iodine see also 3,5,044, 5,4,060	

EURSAFE bottom up approach: from more than 1000 phenomena to 21 items for needed research

Number of entries	In-vessel	Ex-vessel	Dynamic loading	Long term loading	Fission products	Sum
Phenomenon identification	162	149	460	116	128	1014
Selected due to high importance for safety	43	48	82	36	30	239
Selected due to significant lack of knowledge	24	28	26	10	18	106
Integrated items for needed research	6	4	5	1	5	21

No	Items for needed Research	Rationale for selection
5,3	Aerosol behaviour impact on source term	Quantify the source term for aerosol retention in the secondary side of steam generator and leakage through cracks in the containment wall as well as the source into the containment due to revolatilisation in RCS.

Review of Work 1/3

- EURSAFE methodology has been proven as adequate
- Check of research performed in SARNET
 - EURSAFE Research Items not covered at all
 - ★ Integrity of RCS, distribution of decay heat, containment bypass
 - ★ Dynamic and static behaviour of containment, crack formation
 - ★ Characterisation and quantification of fission product release during core re-flooding
 - EURSAFE Research Items not appropriately covered
 - ★ Coolability of particulate debris bed in case of reflooding, 2/3-D effects
 - ★ Ex-vessel corium coolability, scale effects not adequately addressed

Review of Work 2/3

- New research items or items with reoriented objectives 1/2
 - Physical resuspension in the circuit (should be evaluated)
 - ★ EURSAFE Reference Number 5,2,042: Quantify the source term for aerosol retention in the secondary side of steam generator and leakage through cracks in the containment wall as well as the source into the containment due to revolatilisation in RCS
 - ★ Safety oriented Votes for Source Term = 2.20 (PoV not evaluated)
 - ★ New consolidated findings for safety and risk relevance
 - Ruthenium behaviour in the containment (should be evaluated)
 - ★ EURSAFE Reference number 5,1,26: Important increase of the volatility of certain elements due to a high state of oxidation, e.g. in the situation of air ingress in the core
 - ★ Safety oriented Votes for Source Term = 2.36 (PoV = 2.68)
 - ★ Selected for In-vessel release but not for containment behaviour

Review of Work 3/3

- New research items or items with reoriented objectives 2/2
 - Interaction of PARS with iodine (should be evaluated)
 - ★ EURSAFE Reference number 5,5,26: Volatilisation and decomposition of airborne iodides due to violent heat-up induced by hydrogen burning or recombiner
 - ★ Safety oriented Votes for Source Term = 2.08 (PoV not evaluated)
 - ★ New consolidated findings for safety and risk relevance
- Up to now no resolved issue has been recognized
- Development of strategy to
 - Close the issue
 - Initiate reorientation of research items
 - Launch new research items

Justification of Research Priorities

- Collect demand from working groups
- Assess work progress presented and documented by the working groups
- Evaluate safety and risk relevance of the selected items
- Check for lack of knowledge
- Make decisions traceable
- Make use of already available information
- Develop a strategy based on EURSAFE experience

Structure of Strategy Template

- Possible actions to be performed and documented:
 - a. Recall descriptions and evaluation from EURSAFE
 - b. Rationale for the decision to be taken
 - c. Evaluation by means of knowledge, test facility, model development
 - d. Review and assessment by means of safety and risk significance
 - e. Review of decision, inform GB
 - f. Publication on ACT and ask SARNET and End User for comment
 - g. Comments from SARNET community and End User
 - h. Compile comments and reassess PoV and SoV
 - i. Review of decision, ask GB for endorsement
 - j. Final description of objectives, experimental programme, and codes

Actors in the decision process: Member of Working Groups and its organisations

End User	Decisions in cooperation with Governing Board		Safety oriented Votes		Topic	Scientific coordination, Phenomenon oriented Votes		
	Management Team		SARP Team			Topical Coordinator	Task Leader	
TSO, Industry, Utilities, etc	Adroguer, B	IRSN	Clement, B	IRSN	ASTEC	V.-Dorsselaere	IRSN	
	Annunziato, A	JRC	Dinh, Nam	KTH			V.-Dorsselaere	IRSN
	Beraha, D	GRS	Ducros G	CEA	PSA	Bonnet, JM	CEA	
	Bonnet, JM	CEA	Dutheillet, Y	EDF			Corium	FZK; IRSN; IRSN
	Chaumont, B	IRSN	Ivanov, I	TUS	Containment	Meyer, L	KTH; IRSN	
	Haste, T	PSI	Lindholm, I	VTT			IKE; CEA; CEA	
	Meyer, L	FZK	Picherau, F	IRSN			Wilkening, H	JRC
	Micaelli, JM	IRSN	Ranval, W	EDF	Source term	Haste, T	PSI	
	Sehgal, BR	KTH	Scholtyssek,W	FZK			Giordano,P	IRSN
	Trambauer, K	GRS	Sehgal, BR	KTH			Herranz, L	CIEMAT
	V.-Dorsselaere	IRSN	Seiler, JM	CEA				
			Trambauer, K	GRS				

WP_9: Steinbrueck, M; Seiler, N; Repetto, G. WP10: Park, SH; Koundy, V. WP11: Buerger, M; Spindler, B; Journeau, C.

Strategy plan of decision process: Issue is resolved

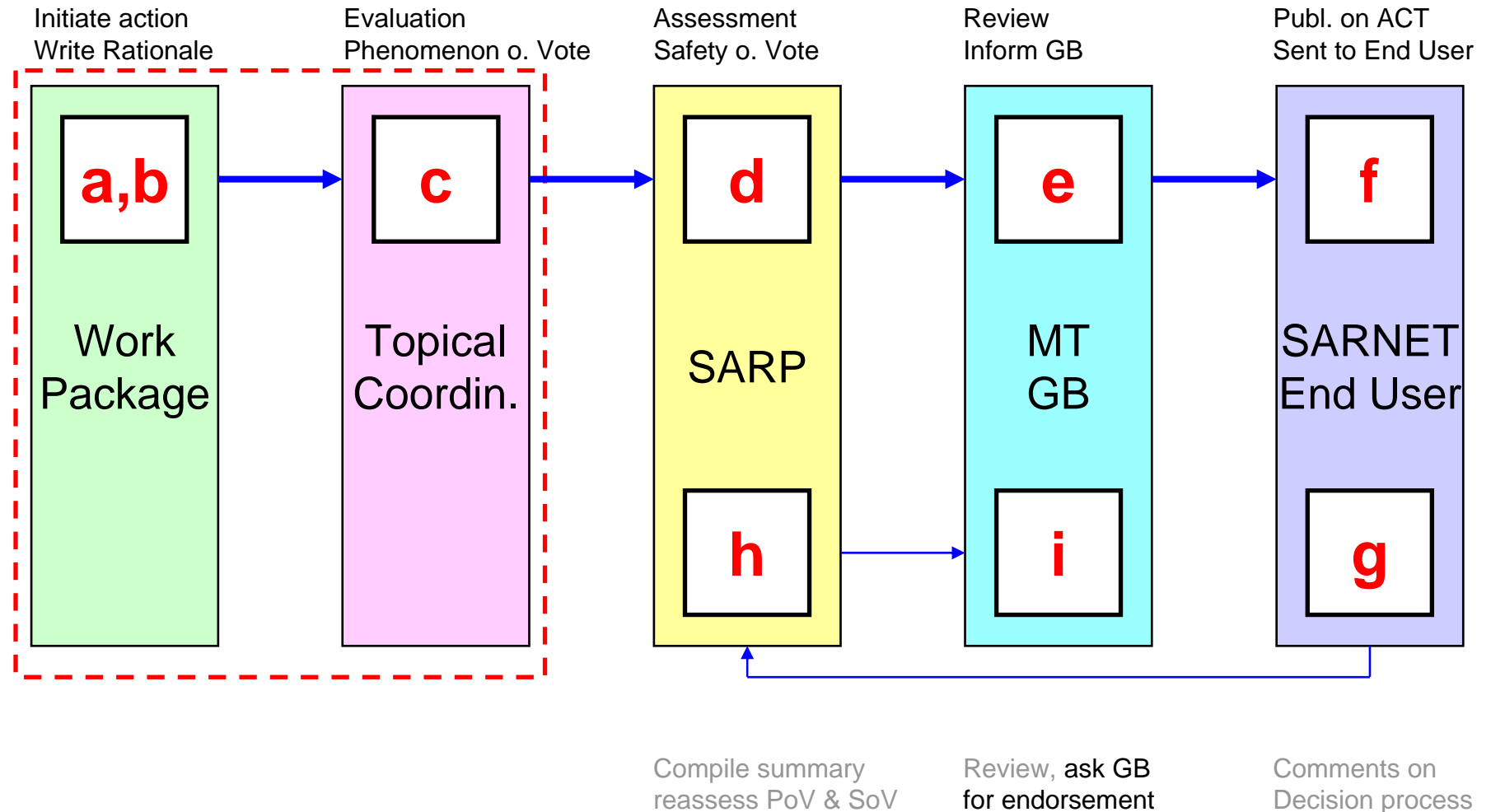

Strategy plan of decision process: Reorientation of item

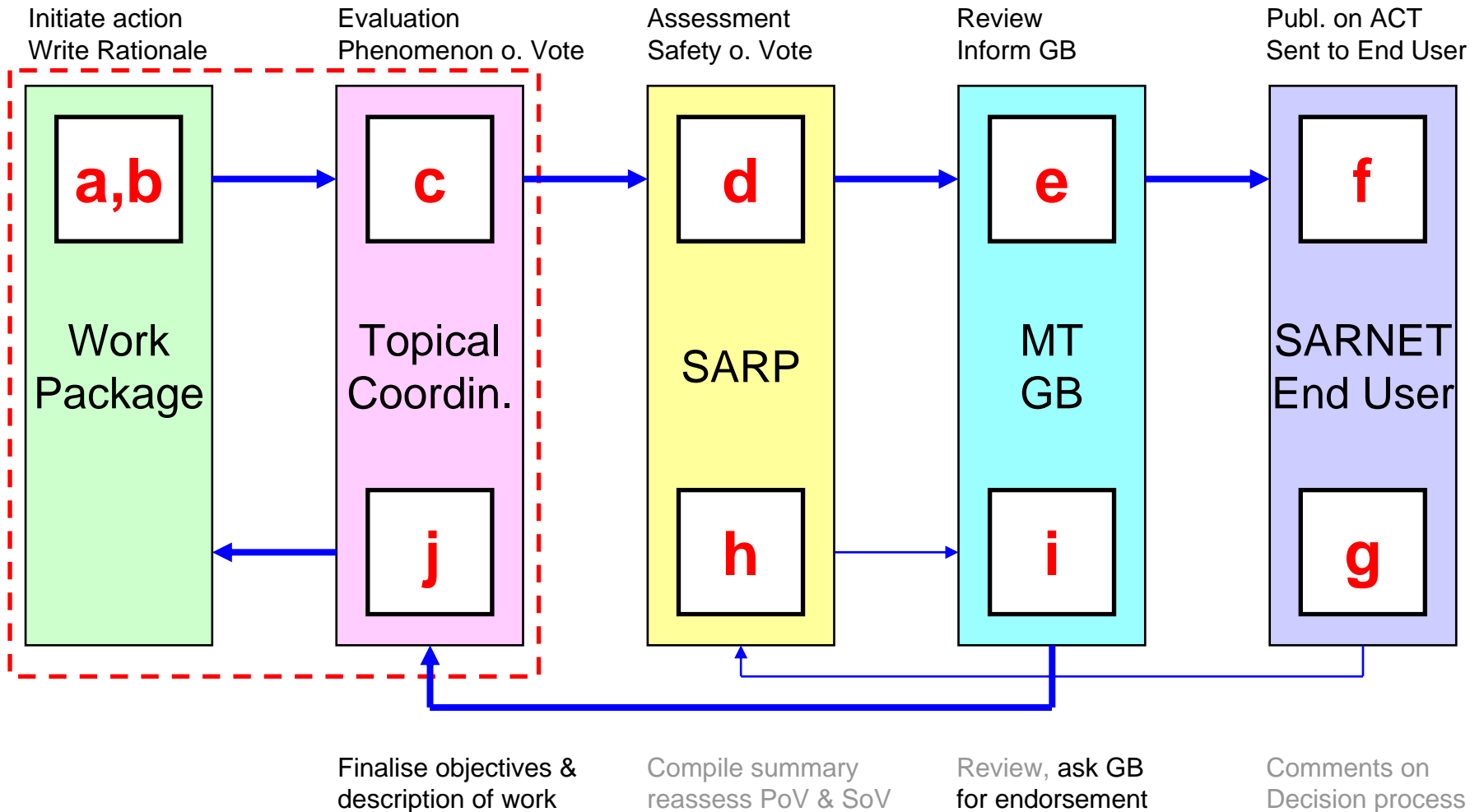

Strategy plan of decision process: Launch new R&D item

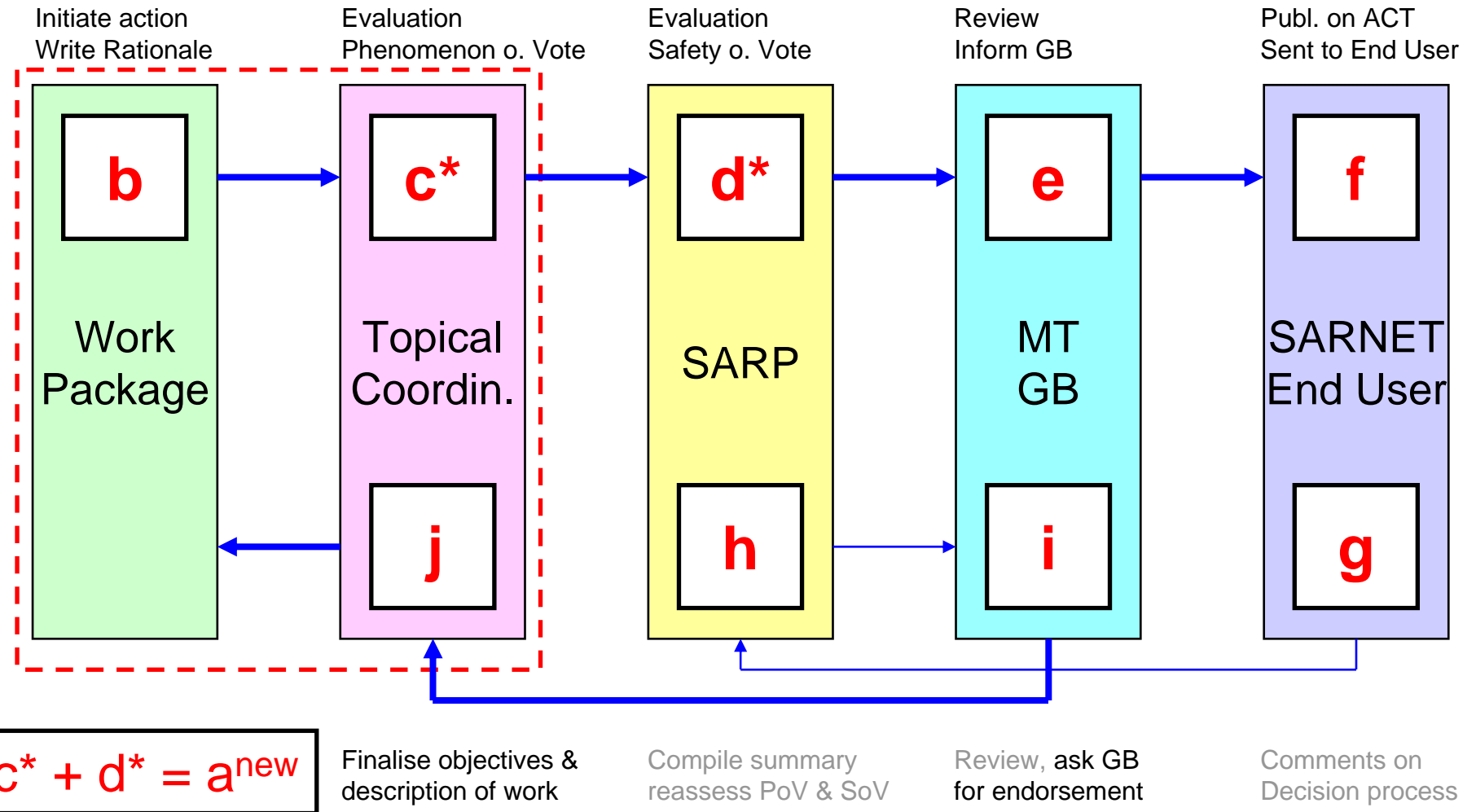

Link of ERMSAR with SARP

- Review European severe accident research
 - Identify progress made by means of increase of knowledge
 - Identify research areas which need reorientation
 - Identify research needs not being covered by SARNET
- Session 8:
 - General discussions
 - Conclusions and recommendations
- Provide input for SARP
 - ERMSAR presentations should consider these main tasks

Acknowledgement

The research and developmental work of GRS are sponsored by the German Federal Ministry of Economics and Labour BMWA.

Thank you for your attention