



"NUCLEAR FISSION "
Safety of Existing Nuclear
Installations



Contract FI6O-CT-2004-509065

SARNET

Network of Excellence for a Sustainable Integration of European Research on
Severe Accident Phenomenology

Other Activities in the field of Nuclear Technologies and Safety, Safety of Existing Nuclear Installations

**SARNET-MANAG-D95
DPAM/DIR-2007-089**

**JOINT PROGRAMME OF ACTIVITIES, UPDATE 3
Draft planning for the Month 37 – Month 54 Period
(JPA4)**

April 2007 – September 2008

T. Albiol, B. Adroguer, J.P. Van Dorsselaere (IRSN-DPAM)
B. Chaumont (IRSN-DSR)
T. Haste (PSI)
C. Journeau (CEA-DEN)
L. Meyer (FZK)
B. Schwinges, D. Beraha (GRS)
A. Annunziato (JRC-ISPRA)
R. Sehgal (KTH)

For Deliverables, due date: May 2007	Actual submission date: May 2007
For other doc., period covered: April 2007 – September 2008	
Start date of SARNET: April 1, 2004	Duration: 4 years, plus potential extension
WP No: WP20 Lead topical coordinator: T. Albiol	His organization name: IRSN



**Project co-funded by the European Commission under the Euratom Research and Training Programme on
Nuclear Energy within the Sixth Framework Programme (2002-2006)**

Dissemination Level

PU	Public	x
RE	Restricted to a group specified by the partners of the SARNET project	
CO	Confidential, only for partners of the SARNET project	

SARNET Quality Assurance page

Partner responsible for the document: IRSN	
Nature of document	Deliverable
Reference(s)	SARNET-MANAG-D95 IRSN/DPAM/DIR-2007-089
Title	Joint programme of activities, update 3; draft planning for the month 37 – month 54 period (JPA4)
Author(s)	T. Albiol, B. Adroguer, J.P. Van Dorsselaere (IRSN-DPAM); B. Chaumont (IRSN-DSR); T. Haste (PSI) ; C. Journeau (CEA-DEN); L. Meyer (FZK); B. Schwinges, D. Beraha (GRS); A. Annunziato (JRC-ISPRA); R. Sehgal (KTH)
Delivery date	May 2007
Topical area	Management
For Journal & Conf. papers	- -
<p><u>Summary:</u></p> <p>This document describes the work to be performed in the frame of the SARNET contract with the EC (Contract FI6O-CT-2004-509065), during the 18-month period from April 2007 to September 2008. This 18-month period already anticipates an extension from the initial contract (which ends on March 31st, 2008), under discussion with the EC.</p> <p>The total effort is estimated to about 850 person-months and the total cost to about 10.7 M€. The main measurable objectives of the JPA4 are:</p> <ul style="list-style-type: none"> - the organisation of ERMSAR 2007, European Review Meeting on Severe Accident Research; this event will be organised in June 2007 at Karlsruhe (Germany). - the organisation of one (or tentatively 2) course on severe accident with a focus either on analysis or on CANDUs and VVERs or on PSA and SAM. - the final synthesis of ASTEC V1 assessment in October 2008. - the finalized version of an integrated R&D SA programme associated to the ranking of research priorities. This document will describe the strategy proposed by SARNET to tackle the pending issues important for reactor safety in the coming years. - the final draft of the SA book. - the negotiation of a 6-month extension of the current SARNET contract, at constant budget. - the release of a revision of SARNET Consortium Agreement to be applied beyond the end of the current contract with the EC, for a new contract before reaching real self-sustainability of the network. 	

Visa grid			
	Main author(s)	Verification	Approval
Name (s)	T Albiol (IRSN)	J.P. Van-Dorsselaere (IRSN)	T. Albiol (IRSN)
Date	11/04/2007	12/04/2007	14/05/2007
Signature			

Distribution of the report

Available on ACT (SARNET internal Web site)

Electronic distribution to:

Governing Board members and/or technical correspondents + Management Team + European Commission

COMP. short	COMP. N.	SURNAME	FIRST NAME	E-MAIL
IRSN	1	ADROGUER	Bernard	bernard.adroguer@irsn.fr
IRSN	1	ALBIOL	Thierry	thierry.albiol@irsn.fr
IRSN	1	CHAUMONT	Bernard	bernard.chaumont@irsn.fr
IRSN	1	MICAELLI	Jean-Claude	jean-claude.micaelli@irsn.fr
IRSN	1	SOUCHET	Yves	yves.souchet@irsn.fr
IRSN	1	VAN DORSSELAERE	Jean-Pierre	jean-pierre.van-dorsseleere@irsn.fr
WMTL	2	DICKINSON	Shirley	shirley.dickinson@wmt.co.uk
AEKI	3	HOZER	Zoltan	hozer@sunserv.kfki.hu
ARCS	4	SDOUZ	Gert	gert.sdouz@arcs.ac.at
AVN	5	VAN HAESENDONCK	Michel	mvh@avn.be
BUTE	6	ASZODI	Attila	aszodi@reak.bme.hu
CEA	7	BONNET	Jean- Michel	jean-michel.bonnet@cea.fr
CEA	7	BOUCHTER	Jean-Claude	jean-claude.bouchter@cea.fr
CEA	7	CHALAYE	Hervé	herve.chalaye@cea.fr
CEA	7	JOURNEAU	Christophe	christophe.journeau@cea.fr
CEA	7	LABATUT	Michel	michel.labatut@cea.fr
CESI RICERCA	8	PAROZZI	Flavio	flavio.parozzi@cesiricerca.it
CHALMERS	9	SIHVER	Lembit	sihver@chalmers.se
CIEMAT	10	HERRANZ	Luis Enrique	luisen.herranz@ciemat.es
CSN	11	IZQUIERDO ROCHA	Jose Maria	jmir@csn.es
DEMOKRITOS	12	HOUSIADAS	Christos	christos@ipta.demokritos.gr
UPI	13	ORIOLO	Francesco	oriolo@ing.unipi.it
UPI	13	PACI	Sandro	s.paci@ing.unipi.it
EA	14	DOMINGUEZ	Maria-Theresa	mdb@empre.es
EA	14	ROQUE	Perezagua	plr@empre.es
EDF	15	HUTIN	Jean-Pierre	jean-pierre.hutin@edf.fr
EDF	15	LABADIE	Gérard	gerard.labadie@edf.fr
ENEA	16	DE ROSA	Felice	felice.derosa@bologna.enea.it
FORTUM	17	ROUTAMO	Tomi	tomi.routamo@fortum.com
FRA ANP SAS	18	AZARIAN	Garó	garo.azarian@framatome-anp.com
FRA ANP GmbH	19	EYINK	Juergen	juergen.eyink@framatome-anp.com
FRA ANP GmbH	19	KURSAWE	Hans Michael	Hans-Michael.Kursawe@framatome-anp.com
FZJ	20	REINECKE	Ernst A.	e.-a.reinecke@fz-juelich.de
FZK	21	KNEBEL	Joachim	joachim.knebel@psf.fzk.de
FZK	21	MEYER	Leonhard	Leonhard.Meyer@iket.fzk.de
FZK	21	SCHOLTYSSEK	Werner	werner.scholtyssek@psf.fzk.de
FZR	22	ALTSTADT	Eberhard	E.Altstadt@fz-rossendorf.de
GRS	23	ALLELEIN	Hans-Josef	hans-josef.allelein@grs.de
GRS	23	BERAHA	David	bea@grs.de
GRS	23	SCHWINGES	Bernd	Bernd.Schwinges@grs.de
GRS	23	TESCHENDORFF	Viktor	tes@grs.de
GRS	23	TRAMBAUER	Klaus	trb@grs.de
USTUTT-IKE	24	BUERGER	Manfred	buerger@ike.uni-stuttgart.de
INR	25	GHEORGHU	Constantin	dirsticn@artelecom.net
INR	25	TURCU	Ilie	turcugx@xnet.ro
INRNE	26	GRUDEV	Pavlin Petkov	pavlinpg@inrne.bas.bg

IVS	27	MATEJOVIC	Peter	ivstt@nexta.sk
JRC IPSC	28	ANNUNZIATO	Alessandro	alessandro.annunziato@jrc.it
JRC ITU	29	BOTTOMLEY	David	bottomley@itu.fzk.de
JRC ITU	29	GLATZ	Jean-Paul	glatz@itu.fzk.de
JRC IE/ITU/IPSC	30	WILKENING	Heinz	heinz.wilkening@jrc.nl
JRC IE/ITU/IPSC	30	ZEYEN	Roland	roland.zeyen@irsn.fr
JSI	31	LESKOVAR	Matjaz	matjaz.leskovar@ijs.si
JSI	31	MAVKO	Borut	borut.mavko@ijs.si
KTH	32	DINH	Truc-Nam	namdinh@safety.sci.kth.se
KTH	32	SEHGAL	Bal Raj	bsehgala@safety.sci.kth.se
LEI	33	KALIATKA	Algirdas	algis@isag.lei.lt
LEI	33	USPURAS	Eugenijus	eugeniju@mail.lei.lt
NNC	34	GRINDON	Liz	liz.grindon@amecnnc.com
NRG	35	WAKKER	Pieter	wakker@nrg-nl.com
NRG	35	WICHERS	Victor A.	Wichers@nrg-nl.com
PSI	36	GUENTAY	Salih	salih.guentay@psi.ch
PSI	36	HASTE	Tim	tim.haste@psi.ch
RUB	37	KOCH	Marco	koch@lee.rub.de
RUB	37	WAGNER	Hermann-Josef	lee@lee.rub.de
SWP	39	GUSTAVSSON	Veine	veine.gustavsson@vattenfall.com
TA	40	ARNOULD	François	francois.arnould@technicatome.com
THERMODATA	41	CHEYNET	Bertrand	bertrand.cheynet@grenet.fr
TE	42	AUGLAIRE	Michèle	michele.auglaire@tractebel.com
TE	42	VANHOENACKER	Luc	Luc.Vanhoenacker@tractebel.com
TUS	43	IVANOV	Ivan	ivec@tu-sofia.bg
ULB	44	LABEAU	Pierre-Etienne	pelabeau@ulb.ac.be
UJD	46	HUSARCEK	Jan	jan.husarcek@ujd.gov.sk
UJV	47	DIENSTBIER	Jiri	die@ujv.cz
UJV	47	JAKAB	Jan	jak@ujv.cz
UPM	48	GALLEGO	Eduardo	eduardo.gallego@upm.es
VEIKI	49	TECHY	Zsolt	techy@aed.veiki.hu
VTT	50	LINDHOLM	Ilona	ilona.lindholm@vtt.fi
VTT	50	PUSKA	Eija-Karita	eija-karita.puska@vtt.fi
VUJE	51	BREZNA	Alena	brezna@vuje.sk
VUJE	51	JANCOVIC	Juraj	Jancovic@vuje.sk
BTech	52	FISCHER	Karsten	fischer@becker-technologies.com
BTech	52	POSS	Gerhard	poss@becker-technologies.com
AECL	53	BUSHBY	Stephen	bushbys@aecl.ca
AECL	53	GLOWA	Glen A.	glowag@aecl.ca
BNRA	54	AVDJIEV	Krassimir	k.avdjiev@bnsa.bas.bg
UNEW	55	TUCK	Alan	alan.tuck@newcastle.ac.uk
EC		HUGON	Michel	michel.hugon@ec.europa.eu
EC expert (ERI)		KHATIB-RAHBAR	Mohsen	mkr1@eri-world.com
EC expert (SKI)		LÖWENHIELM	Gustaf	gustaf.lowenhielm@ski.se
EC expert		ROYEN	Jacques	icn.royen@wanadoo.fr

Table of Contents

1	INTRODUCTION	6
2	CONTRACTOR LIST	6
3	THE SARNET ACTIVITIES	9
3.1	SARNET ASSOCIATED PROGRAMMES	10
3.1.1	<i>ASTEC</i>	10
3.1.2	<i>Research programmes</i>	11
	Resolution of Corium issues	11
	Resolution of containment issues	13
	Resolution of source term issues	14
3.1.3	<i>Level 2 PSA</i>	16
3.2	JOINT PROGRAMME OF ACTIVITIES (JPA)	16
3.2.1	<i>Integrating activities (JPA/IA)</i>	17
	WP1: Advanced Communication Tool.....	17
	WP2, 3, 4: Integral Code ASTEC.....	19
	WP5: Level 2 PSA.....	22
	Implementation of scientific databases.....	27
	Research priority assessment.....	28
	Integration assessment.....	30
3.2.2	<i>Programme for Jointly executed Research Activities (JPA/JRA)</i>	30
	Resolution of corium issues.....	31
	Resolution of containment issues	35
	Resolution of Source Term issues	36
3.2.3	<i>Activities designed to spread excellence</i>	36
3.2.4	<i>Management activities</i>	38
3.3	PLAN FOR USING AND DISSEMINATING KNOWLEDGE.....	39
3.4	MAJOR MILESTONES OVER FULL PROJECT DURATION.....	39
4	QUALITY OF INTEGRATION AND PERFORMANCE INDICATORS.....	41
5	DETAILED JOINT PROGRAMME OF ACTIVITIES N°4 (JPA4) – MONTH 37 TO MONTH 54.....	42
5.1	INTRODUCTION – GENERAL DESCRIPTION, MILESTONES, MEASURABLE OBJECTIVES	42
5.2	WORK PACKAGE LIST/OVERVIEW	43
5.3	GRAPHICAL PRESENTATION OF WORK PACKAGES	45
5.4	DETAILED DESCRIPTION, PLANNING AND TIME TABLE	45
5.5	LIST AND STATUS OF SARNET DELIVERABLES.....	79
6	PROJECT RESOURCES AND ESTIMATION OF INCURRED ELIGIBLE COSTS	85
6.1	EFFORTS FOR THE FULL DURATION OF THE PROJECT (AS DEFINED AT THE BEGINNING OF THE PROJECT).....	85
6.2	EFFORTS FOR THE FULL DURATION OF THE PROJECT (AS DEFINED AFTER 36 MONTHS OF OPERATION OF THE PROJECT).....	88
6.3	EFFORTS FOR THE FOURTH JPA 18-MONTH PERIOD (MONTH 37 - MONTH 54)	91
6.4	ESTIMATED BREAKDOWN OF THE REQUESTED EC CONTRIBUTION PER REPORTING PERIOD	100
6.5	PROJECT MANAGEMENT LEVEL, DESCRIPTION OF RESOURCES AND GRANT	100
APPENDIX A- CONSORTIUM DESCRIPTION, NEW CONTRACTORS		104
A.1	UPDATE OF THE LIST OF PARTNER ORGANIZATIONS AND OF SCIENTISTS INVOLVED IN THE NETWORK.....	104
A.2	SUB-CONTRACTING.....	104
A.3	THIRD PARTIES	104

1 Introduction

This document describes the work to be performed in the frame of the SARNET contract with the EC (Contract FI6O-CT-2004-509065), during the 18-month period from April 2007 to September 2008. This 18-month period already anticipates an extension from the initial contract (which ends on March 31st, 2008), under discussion with the EC.

The Chapter 2 gives the updated list of participants.

The Chapter 3 is an updated description of the JPA.

The Chapter 4 reminds the performance indicators to be monitored during the project.

The Chapters 5 and 6 describe the work to be performed during the JPA4 (April 2007 - September 2008), the required efforts and the incurred eligible costs.

2 Contractor list

Particip. Role*	Particip. Number	Participant name	Participant short name	Country	Date enter project**	Date exit project**
CO	1	Institut de Radioprotection et de Sûreté Nucléaire	IRSN	France	Month 1	EOP
CR	2	AEA Technology Waste Management Technology Ltd	AEAT WMTL	United Kingdom	Month 1 Month 25	Month 24 EOP
CR	3	KFKI Atomic Energy Research Institute	AEKI	Hungary	Month 1	EOP
CR	4	ARC Seibersdorf research GmbH	ARCS	Austria	Month 1	EOP
CR	5	Association Vincotte Nucleaire	AVN	Belgium	Month 1	EOP
CR	6	Budapest University of Technology and Economics Institute of Nuclear Techniques	BUTE	Hungary	Month 1	EOP
CR	7	Commissariat à l'Energie Atomique	CEA	France	Month 1	EOP
CR	8	Centro Elettrotecnico Sperimentale Italiano Giacinto Motta SpA Centro Elettrotecnico Sperimentale Italiano Ricerca Spa	CESI CESI RICERCA	Italy	Month 1 Month 25	Month 24 EOP
CR	9	Chalmers tekniska högskola	CHALMERS	Sweden	Month 1	EOP
CR	10	Centro de Investigaciones Energeticas Medio Ambientales y Tecnologicas	CIEMAT	Spain	Month 1	EOP
CR	11	The Consejo de Seguridad Nuclear	CSN	Spain	Month 1	EOP
CR	12	National Centre for Scientific Research "DEMOKRITOS"	DEMOKRITOS	Greece	Month 1	EOP

Particip. Role*	Particip. Number	Participant name	Participant short name	Country	Date enter project**	Date exit project**
CR	13	Universita' di Pisa	UPI	Italy	Month 1	EOP
CR	14	Empresarios Agrupados International, S.A.	EA	Spain	Month 1	EOP
CR	15	Electricité de France	EDF	France	Month 1	EOP
CR	16	Ente per le Nuove Tecnologie, l'Energia e l'Ambiente	ENEA	Italy	Month 1	EOP
CR	17	Fortum Nuclear Services Ltd.	FORTUM	Finland	Month 1	EOP
CR	18	Framatome ANP SAS	FRA ANP SAS	France	Month 1	EOP
CR	19	Framatome ANP-Gmbh	FRA ANP-Gmbh	Germany	Month 1	EOP
CR	20	Forschungszentrum Juelich GmbH	FZJ	Germany	Month 1	EOP
CR	21	Forschungszentrum Karlsruhe GmbH	FZK	Germany	Month 1	EOP
CR	22	Forschungszentrum Rossendorf e.V.	FZR	Germany	Month 1	EOP
CR	23	Gesellschaft für Anlagen- und Reaktorsicherheit mbH	GRS	Germany	Month 1	EOP
CR	24	University of Stuttgart	IUSTT-IKE	Germany	Month 1	EOP
CR	25	National Autonomous Company for Nuclear Activities Nuclear Research Subsidiary Pitesti	INR	Romania	Month 1	EOP
CR	26	Institute for Nuclear Research and Nuclear Energy	INRNE	Bulgaria	Month 1	EOP
CR	27	Inzinierska Vypoctova Spolocnost Trnava Ltd	IVS	Slovakia	Month 1	EOP
CR	28	EURATOM Joint Research Center of ISPRA	JRC ISPRA	European Union	Month 1	EOP
CR	29	EURATOM Joint Research Center Trans Uranian Institute	JRC ITU	European Union	Month 1	EOP
CR	30	EURATOM Joint Research Center of Petten	JRC PETTEN	European Union	Month 1	EOP
CR	31	Jozef Stephan Institute	JSI	Slovenia	Month 1	EOP
CR	32	Kungl Tekniska Högskolan	KTH	Sweden	Month 1	EOP
CR	33	Lithuanian Energy Institute	LEI	Lithuania	Month 1	EOP
CR	34	National Nuclear Corporation Ltd	NNC	United Kingdom	Month 1	EOP
CR	35	Nuclear Research &	NRG	The	Month 1	EOP

Particip. Role*	Particip. Number	Participant name	Participant short name	Country	Date enter project**	Date exit project**
		Consultancy Group v.o.f.		Netherlands		
CR	36	Paul Scherrer Institut	PSI	Switzerland	Month 1	EOP
CR	37	Ruhr-Universität Bochum	RUB	Germany	Month 1	EOP
	38					
CR	39	Swedpower AB	SWP	Sweden	Month 1	EOP
CR	40	Technicatome	TA	France	Month 1	EOP
CR	41	Thermodata	THERMODATA	France	Month 1	EOP
CR	42	Suez-Tractebel SA	TE	Belgium	Month 1	EOP
CR	43	Technical University of Sofia	TUS	Bulgaria	Month 1	EOP
CR	44	Université Libre de Bruxelles	ULB	Belgium	Month 1	EOP
CR	45	Université Catholique de Louvain	UCL	Belgium	Month 1	EOP
CR	46	Urad Jadroveho Dozoru SR	UJD	Slovakia	Month 1	EOP
CR	47	Ustav Jaderneho Vyzkumu Rez a.s.	UJV	Czech Republic	Month 1	EOP
CR	48	Universidad Politecnica de Madrid	UPM	Spain	Month 1	EOP
CR	49	VEIKI Institute for Electric Power Research Co.	VEIKI	Hungary	Month 1	EOP
CR	50	VTT Technical Research Centre of Finland	VTT	Finland	Month 1	EOP
CR	51	VUJE Trnava, a.s. – Inzinierska, Projektova a Vyskumna Organizacia	VUJE	Slovakia	Month 1	EOP
CR	52	Becker Technologies GmbH	BTech	Germany	Month 1	EOP
CR	53	Atomic Energy of Canada Limited	AECL	Canada	Month 25	EOP
CR	54	Nuclear Regulatory Agency of Bulgaria	BNRA	Bulgaria	Month 25	EOP
CR	55	New Castle University	UNEW	United Kingdom	Month 25	EOP

* CO = Coordinator
CR = Contractor

** EOP = End of Project

WARNING:

- **Participants 28, 29 and 30 are a unique contractor legal entity: EC-JRC.**
- **There is no contractor N°38.**
- **The contractor N°45 has stopped his SARNET activities at the end of JPA1 but has not been formally withdrawn from the Partners list.**
- **Participants 53 to 55 are new participants since the beginning of JPA3.**

3 The SARNET activities

The SARNET activities consist of:

- the R&D activities carried out by SARNET members in the frame of national or international programmes, contributing to the resolution of remaining issues identified in the EURSAFE project then through the work of the SARNET Work-package 07 on Severe Accident research priorities;
- a complementary programme jointly carried out, called Joint Programme of Activities (JPA) and aiming at:
 - o progressively integrating the above national/international research programmes,
 - o initiating and launching new programmes jointly carried out by sustainable research groups,
 - o capitalizing the acquired knowledge in the integral code ASTEC and in data bases,
 - o diffusing knowledge.

The JPA constitutes the kernel of SARNET. Such activities give the orientations to be followed, in terms of research and work distribution between SARNET members. They build the necessary links between national programmes, facilitate the necessary transfers of information (inside and outside the network), and organize the work partition in order to make the most of available competences and means.

The JPA can be broken down into 4 main activities:

- Integrating Activities to strengthen links between organisations;
- Joint Research Activities to pilot the research activities addressing remaining outstanding issues, to elaborate synthesis, and programme proposals;
- Spreading of Excellence Activities;
- Management Activities.

The ASTEC code is the main integrating component and is one of the gathering places of the knowledge. It contributes to the diffusion of this knowledge efficiently. Activities linked to ASTEC will thus appear as “*Integrating Activities*”, whereas some of them contribute also to the range of “*Spreading of Excellence Activities*”. Concerning “*Joint Research Activities*”, most of them have links with ASTEC, as one of their ultimate goals consists in providing physical models to be integrated in ASTEC. Furthermore, the exchange of information on the detailed models developed by the various experts through interpretation of experiments will lead at medium and long term to generic common models used in the different detailed codes (example of ICARE/CATHARE and ATHLET-CD). Besides, adequate models are derived from these detailed models and will be included in the common reference ASTEC code.

The R&D needs are periodically updated and the objectives of future experiments are defined taking into account the outcome of the collaborative work on risk studies. A consensus should be reached on closure of some issues and would allow redistributing competence and manpower on open ones in concert with other international projects (e.g. ISTC, OECD projects...).

Most of the JPA elements are interlinked: for instance, experimental database activity and ASTEC physical assessment; or model recommendation formulated in the Joint Research Activities and model implementation in ASTEC. This contributes to tighten the links between the different participants to these activities (horizontal integration).

The R&D activities surrounding the JPA and connected to it are mainly:

- the GRS-IRSN programme aiming at developing the integral code ASTEC and making it open and available for all SARNET partners,

- the diverse national research activities (experimental programmes, related interpretation and modelling activities) that aim at resolving open issues identified as important and of common interest in EURSAFE conclusions (and their updates),
- the development of Level 2 PSA methodologies, the results of which will provide inputs for the definition of research priorities elaborated by SARNET partners.

These key programmes are called SARNET Associated Programmes (SAP) in the rest of the document.

The JPA clearly constitutes the active link connecting all these associated programmes and making, in a sustainable way, the whole system more and more efficient.

Beyond programmes carried out by SARNET contractors, some external programmes are taken into account:

- ISTC projects,
- OECD projects,
- and more generally, programmes of interest carried out by non-SARNET members or non-European organizations (i.e. specific VVER joint research programmes, ...).

It is a priority task of the Consortium to define the way to associate or integrate these programmes and the involved teams, when there are in a position to complement in a sustainable way the competence and expertise of SARNET in domains of importance. During the first SARNET years the interactions between SARNET and the CEG-SAM (Contact Expert Group on Severe Accident Management) of ISTC have been defined in order to integrate in SARNET activities results of ISTC projects devoted to Severe Accident and to provide SARNET input in the definition of ISTC project test matrices.

3.1 SARNET Associated Programmes

As said previously, the main elements of these associated programmes are:

- ASTEC development by GRS and IRSN,
- Research programmes carried out in organizations which are members of the network, (experimentation, interpretation and modelling),
- Current Level 2 PSA methodology developments.

They are described below in order to give the boundary conditions of the JPA, main component of the present SARNET contract.

3.1.1 ASTEC

The ASTEC code that is jointly developed by IRSN and GRS describes the complete behaviour of a NPP under severe accident conditions. It is extensively used by IRSN for Level 2 PSA regarding 900 and 1300 MWe Pressurized Reactors. It behaves as the main integrator of knowledge in SARNET and contributes to diffuse this knowledge to all members.

For the 18-month period corresponding to this JPA4 report (April 2007 to September 2008), only the release of updates (rev1, rev2...) of the latest ASTEC V1.3 version is foreseen because IRSN and GRS accentuate their development efforts in the frame of the future V2 series of ASTEC versions (see below). The partners will thus assess these successive ASTEC V1.3 update versions.

The future versions V2 will account for the inputs provided by different SARNET tasks and Work-Packages of the JPA. In particular, the 1st version, to be released in 2nd part of 2008, thus beyond SARNET current contract end, will include the ICARE2 code (IRSN) as module for core degradation and will simulate the EPR. IRSN and GRS will also integrate the model proposals elaborated in the frame of Joint Research Activities.

3.1.2 Research programmes

Such activities concern experimental programmes, interpretation work and/or modelling activities. EURSAFE highlighted some remaining important safety issues, which can be broken down into:

- corium issues,
- containment issues,
- source term issues.

Current and future activities to be carried out by partners with the objective to solve the above-mentioned issues have been selected for SARNET. More precisely, they consist in:

- performing new experimental work (separate-effect or integral tests) and preparing/interpreting it with models or codes;
- interpreting already performed experiments with models or codes;
- performing scenario sensitivity studies in reactor conditions with models or codes in order to target actual conditions in the experiments or to investigate the influence of various models or model options;
- modelling activities.

Resolution of Corium issues

In vessel phenomena

The issues identified in the 5th FWP EURSAFE project concerning in-vessel phenomena are:

- Water injection (hydrogen generation, core coolability, ex-vessel corium coolability);
- Late-phase in-vessel degradation and loss of Reactor Pressure Vessel (RPV) integrity (molten pool/debris behaviour in the lower plenum);
- Lower head failure and corium release to cavity;
- Specific remaining issues on early-phase degradation (including B₄C effects from control rods and oxidation by air or steam/air mixtures),
- Reactor Cooling System (RCS) integrity including risk of induced breaks in steam generators.

Additional items have been added in the continuation of COLOSS European project according to their importance for fuel behaviour and fission product release: the B₄C effects and the oxidation by air or steam/air mixtures

For each one, experimental and interpretation activities have been initiated in the frame of national programmes. These programmes may be classified into six topics:

- T1: Hydrogen generation during core reflooding;
- T2: Core and debris coolability during reflooding, including ex-vessel debris bed coolability;
- T3: Late phase core degradation and corium behaviour in lower head, including in-vessel melt retention strategies;
- T4: Vessel failure and release into cavity;
- T5: Early phase degradation and boron carbide effects.
- T6: Zircaloy oxidation by air or steam/air mixture.

The concerned experimental programmes underway (or planned) by the SARNET organisations and to be considered as associated programmes are given in the table below (some updates may be missing):

NAME	Topic	Leading organisation
Vessel external cooling facility	T3	CEA

DEBRIS	T2	IUSTT-IKE
DEFOR, MISTEE-J, POMECCO-U	T2	KTH
FOREVER, SIMECCO	T4, T3	KTH
LIVE	T3	FZK
MAESTRO platform	T1, T5, T6	IRSN
PHEBUS FP	T3, T5	IRSN
QUENCH and SETs	T1, T5, T6	FZK
STYX	T2	VTT

The interpretation of experiments is carried out with different models or codes (ICARE/CATHARE, SCDAP/RELAP5, SCDAPSIM, ATHLET-CD, KESS, MELCOR, ASTEC).

Among all needs of R&D identified in EURSAFE, only two in-vessel phenomena are not currently covered by experimental proposals: “Effect of Lower-head penetrations in case of external cooling” (very dependent on NPP design) and “Steam generator plenum and tube failure”. They refer to thermal hydraulics studies and should be examined later on.

Ex-vessel phenomena

Likewise, the issues identified in the 5th FWP EURSAFE and EUROCORE projects concerning ex-vessel phenomena are:

- T7: MCCI: molten pool configuration and concrete ablation;
- T8: Ex-vessel corium coolability, top flooding;
- T9: Ex-vessel corium catcher: corium ceramics interaction and properties;
- T10: Ex-vessel corium catcher: coolability and water bottom injection.

These items have been selected with the following rationales:

- Improve predictability of axial versus radial ablation up to late phase MCCI to determine basemat failure time and loss of containment integrity;
- Increase the knowledge of cooling mechanisms by top flooding the corium pool to demonstrate termination of accident progression and keeping containment integrity;
- Demonstrate the efficiency of specific corium catcher designs by improving the predictability of the corium interaction with corium catcher materials;
- Demonstrate the efficiency of water bottom injection to cool corium pool and its impact on containment pressurisation.

They are addressed in the following experimental programmes to be considered as associated to the network:

NAME	Topic	Leading organisation
ARTEMIS	T7-T9	CEA
COLIMA	T7-T9	CEA
COMECO, POMECCO-U	T8-T10	KTH
COMET	T10	FZK
DECOBI, DEFOR	T10	KTH
VULCANO	T7-T9-T10	CEA

The interpretation of experiments is carried out with different models or codes (WEX, WECHSL, MEDICIS, TOLBIAC, TOLBIAC-ICB, CROCO-2D, MELCOR, KESS, MEWA).

Thermodynamic and material property research

The objective is to develop reference thermodynamic and thermo-physical property databases for a consistent analysis of severe accidents.

In the case of thermodynamic properties, a database exists (NUCLEA), which is already used in computer codes and for severe accident analysis in general. The work in SARNET will mainly be a continuation of the effort of the ENTHALPY project (5th FWP) to complement and improve this database.

In the case of thermo-physical properties, no such a database exists at European level for severe accident analysis. Existing databases cover essentially properties under normal conditions. Works have been already identified with the scope of filling this gap.

The work consists of analytical and experimental activities as follows:

- Thermodynamic properties database NUCLEA (continuation and extension of work performed in ENTHALPY)
 - Assessment, validation, merging, editing and maintenance
 - Develop approaches for coupling the data base with SA codes (ASTEC)
 - Identify the experimental needs for completing the data base
 - Select the most appropriate capability(ies) of the Network to provide the missing data.
- Thermo-physical properties database preparatory work
 - Collect information on systems used by partners in order to find the best solution to normalise corium thermo-physical properties used for severe accident analysis (continuation and extension of work performed in 5TH FWP ECOSTAR project)
 - Make syntheses from existing experimental data
 - Select the most appropriate capability(ies) of the Network to measure properties of first importance still lacking data
 - Develop a reference database.
- Experimental work
 - Measurement of density of liquid Zr, Fe, U
 - Phase diagram of U-O-Zr-Fe systems.

Resolution of containment issues

The issues identified in the 5th FWP EURSAFE project concerning containment phenomena are:

- Hydrogen combustion/detonation and containment atmosphere mixing;
- Fuel-coolant interaction;
- Direct containment heating.

The knowledge about the formation of combustible gas mixtures in containments, local gas composition and potential combustion modes is the basis for hydrogen risk assessment and the development of mitigation strategies for real plants. The experimental and theoretical ongoing research concentrates on the reduction of still existing uncertainties, especially concerning:

- The effects of inhomogeneous hydrogen mixtures effects on combustion;
- Reaction kinetics inside catalytic recombiners (PAR);
- Hydrogen distribution in the different parts of the containment with the risk of high local concentrations, taking account of containment geometry (multi-compartment), mass and energy exchanges coming from phenomena as wall condensation, spray and sump evaporation, but also the effect of recombiners on the gas distribution.

During the first months of SARNET, a consolidation of knowledge in the last domain has been obtained, taking account of results of the associated experimental programmes TOSQAN (IRSN), MISTRA (CEA) and ThAI (BTech) experiments, especially in the framework of the OECD International Standard Problem No. 47 (ISP47). The interpretation of experiments was mainly carried out with ASTEC, COCOSYS, TONUS-0D Lumped-Parameter codes and with CFD codes (TONUS,

GASFLOW, CFX, FLUENT). Several issues were also identified during that time, which need to be further investigated:

- the modelling of saturation conditions (in particular not well modelled in CFD codes)
- the interaction of spray mitigation systems with containment atmospheres
- the interaction of recombiners with the containment atmosphere: hot gases exiting recombiner chimneys create natural convection flows due to thermal buoyancy effects, which affect the distribution and mixing of the different gases within the containment, and therefore the amount of hydrogen that can enter into the recombiners.
- the need to further validate CFD codes on genuinely 3D but well instrumented experiments.

Within the first period In the ENACCEF facility combustion experiments have been performed with hydrogen gradients. In the REKO-3 facility autocatalytic recombiner experiments have been made under controlled conditions with forced flow. This was accompanied by an extensive modelling activity using in-house CFD codes such as TONUS, REACFLOW and REKO-DIREKT and the integral code ASTEC. A special activity will concentrate on modelling of combustion of inhomogeneous hydrogen mixtures by performing a code benchmark using codes such as FLUENT, REACFLOW and TONUS on ENACCEF experiments.

For the estimation of potential consequences of fuel-coolant interactions in real plants, a deeper understanding and an increased knowledge is required about specific processes like premixing, melt fragmentation, and particle heat transfer mode for code modelling and code validation. The experimental programmes TREPAM (CEA) and ECO (FZK) have been finished, and MISTEE (KTH) is on hold. MICRONIS programme (CEA) has been interrupted due to major technical difficulties. KROTOS (CEA) has restarted in May 2006 and will form the main focus of the future work. The interpretation of experimental programmes is carried out with the codes MC3D, IKEJET/IKEMIX, IDEMO-2D and FRADEMO. MATTINA is not used anymore as FZK has stopped direct activities on FCI for the time being. JSI will perform MC3D code assessment and model development.

Regarding direct containment heating, experiments performed with different materials (metal and oxide mixtures) are of importance for real plant applications. The dispersion of melt in the cavity, the reactor compartments and the containment in a scaled geometry of German and French reactors, and also of VVER-1000/320 reactor units 5 and 6 of the Bulgarian Kozloduy NPP, are being performed to determine the pressure increase by Direct Containment Heating. The underway main associated experimental programme is DISCO (FZK). The interpretation of this experimental programme is being carried out with the CFD codes AFDM, MC3D and the system codes CONTAIN, MAAP and ASTEC.

Resolution of source term issues

The issues identified in the 5th FWP EURSAFE project concerning the source term are:

- Effect of air ingress;
- Iodine volatility in the Primary Circuit;
- Containment by-pass in case of Steam Generator Tube Rupture (SGTR);
- Iodine behaviour in containment.

The Severe Accidents Research Priorities Group (SARP - WP7) reviewed the EURSAFE issues index during JPA2, and re-evaluated certain of these based on the evidence currently available. As a result of this, ruthenium behaviour in the containment and the effect of fission product heat-up in passive autocatalytic recombiners (PARs) on the source term are now considered (in WP16). Also, resuspension of deposited aerosols as well as revaporisation is considered in WP15, thus more fully studying effects relevant to a possible late source term. Safety issues not considered in the current programme, such as fission product release during core reflood, will be kept on a watching brief, in particular concerning proposed activities in ISTC, where an active role has been taken in reviewing source-term relevant proposals such as EVAN and VERONIKA.

In addition, the evolution of current NPP operations, as the evolution of fuel management towards higher burn-up and the use of MOX fuel, make it necessary to assess the possible consequences on severe accidents. Assessment of the source term takes on additional importance for future NPPs, as most European Safety authorities require that severe accidents be considered in the design of future power plants.

In the SARNET frame, the following research activities associated with these issues will be carried out.

Several effects of air ingress are being addressed. The impact of oxidising environment on the fuel and on fission products release is being studied through different experimental programmes, consisting of separate-effects experiments to examine the behaviour of fuel rods and especially the release of ruthenium (Ru) species under various oxidizing atmospheres (such as RUSSET, VERDON, AECL experiments and VTT speciation tests). On the theoretical side, reactor scenario studies continue for definition of test conditions in separate-effect experiments; interpretation of experimental programmes will also be continued. The main objective of this research is a better evaluation of the consequences of air ingress on the reactor source term, in particular the source term associated with Ru under oxidising conditions and for various kinds of fuel. Models for ASTEC are being proposed.

The impact of high temperature behaviour of fission products, especially iodine, in the Reactor Coolant System (RCS), is also being investigated in the network. The objective is to improve the predictability of iodine species exiting the RCS to provide the best estimate of the source into the containment. It is well known that such behaviour is difficult to predict due to the importance of non-equilibrium chemistry. Associated programme activities include experimental and theoretical work: separate-effect experiments to examine the species formed in the gas phase above the core in the RCS (such as VERCORS and the now operational CHIP facility), new more general revaporisation/speciation experiments at VTT, analysis of fission products and aerosol transport and speciation in the integral test Phébus FPT2, and analysis of control rod material release (such as in the EMAIC tests), modelling and experimental support for the PWR control rod experiment QUENCH-13, and modelling proposals for ASTEC code.

Some specifics of aerosol behaviour in the reactor have been also identified as an important unresolved issue. The main objective, as recommended by the EURSAFE experts, is to quantify the source term and especially in the case of steam generator tube ruptures which leads to a reactor containment building by-pass. This is being addressed by experimental programmes such as ARTIST, PSAERO, PECA/SGTR and HORIZON (including separate-effect tests on aerosol trapping on the steam generator secondary side) and by theoretical work. The question of revaporisation from previous deposits is being studied through tests with simulants and/or samples from integral experiments (RADSOL and REVAP programmes), while physical resuspension is being considered with analysis of the STORM experiments; this latter work is linked to the SGTR/containment bypass activities. Corresponding interpretation work is being performed, along with modelling proposals for the ASTEC code. Additionally, a model for retention of aerosols while passing through containment cracks (not previously treated in ASTEC) is under development, using results from IRSN tests such as SIMIBE, and further experiments could be carried out within SARNET to help formulate and assess this treatment.

Containment chemistry impact on the source term is still an open issue. The main objective of SARNET activities here is to improve the predictability of the various chemical and physical processes which control iodine behaviour in both the gas and water phases inside the containment. This is now extended to ruthenium behaviour already considered under the air ingress topic, so the whole process of release though to behaviour in the containment is now taken into account. Various phenomena affecting the iodine chemistry in these phases (adsorption/RI formation/radiolytic destruction/ effect of steam condensation/effects of paints) have and are being experimentally investigated in separate-effect tests (EPICUR, PARIS, SISYPHE...) as well as at a larger scale in ThAI. Related interpretation will be carried out, as well as interpretation of iodine behaviour in the

containment of Phébus FPT2. An Iodine Data Manual that provides recommendations for experiments and for iodine codes in the context of their use for reactor safety estimates is in an advanced state of preparation. Activities are progressing on assessment of ruthenium behaviour in the containment, including new experimental work, and on the effect of fission product heat-up on PARs, initially centred on past and present IRSN experimental work (RECI concerning the latter, for example). All this work is leading to modelling proposals for ASTEC.

3.1.3 Level 2 PSA

Several methodologies are used or are under parallel development in organisations needing such a tool for Nuclear Power Plant safety assessment. These uses or developments of methodologies constitute the Associated Programmes related to PSA2.

Main objectives of the JPA are:

- to provide comparisons of these different approaches,
- to promote their harmonisation,
- to share the efforts for the development of new methodologies (particularly dynamic reliability methods).

The JPA is organized into three main topics:

- Sub-project 1 – WP5.1: comparison of Level 2 PSA approaches and identification of improvement needs
- Sub-project 2 – WP5.2: comparison and improvement of methodologies for assessment of uncertainties
- Sub-project 3 – WP5.3: improvement of event tree methodology using dynamic reliability techniques.

3.2 Joint Programme of Activities (JPA)

The Joint Programme Activities can be broken down into 4 series:

- Integrating Activities consisting of:
 - the development of “physical” links between contractors in order to make easier and more flowing the exchange of information,
 - the development of common tools or methodology to enhance the capacity of contractors for harmonizing their research activities (ASTEC, Level 2 PSA);
 - the monitoring of end-users need and the joint elaboration of research priorities;
 - the monitoring of the integration and the elaboration of proposals to integrate further the activities carried out in the frame of SARNET.
- Joint Research Activities consisting of:
 - the elaboration of syntheses, based on the results of the various associated programmes; these syntheses shall lead to scientific consensus on proposal of models to be implemented into ASTEC;
 - the coordination of R&D tasks carried out in the frame of SARNET, with the objective to make the best of available competences and means;
 - the proposal of revision or initiation of programmes with the objective to tackle the major pending issues.
- Spreading of Excellence Activities mainly consisting of education and training, of writing a book and of a mobility programme.
- Management Activities mainly consisting of the administrative tasks.

So, the JPA is divided into 20 work packages (some of these work-packages are divided in sub-work-packages), including 8 on integrating activities, 8 on jointly executed research activities, 3 on spreading of excellence and 1 on management.

3.2.1 Integrating activities (JPA/IA)

The Integrating Activities comprise:

- Implementation of an Advanced Communication Tool for fostering exchange of information;
- Delivery of ASTEC code and support to code users, adaptation of ASTEC to users needs and qualification;
- Harmonization of Level 2 PSA methodology and development of advanced tools;
- Implementation of scientific databases;
- Research priority assessment;
- Integration assessment.

WPI: Advanced Communication Tool

Description

The Advanced Communication Tool (ACT) is a key concept to achieve SARNET goals. Indeed, ACT is the unified support for efficient communication between SARNET partners to achieve the following needs:

- Access, search, publish documents and access codes (concept of knowledge repository),
- Contact and communicate with partners (interactive and collaborative services),
- Joint co-ordination of actions and programmes (co-operative management of the network),
- List links to satellites community projects (R&D projects, related sites).

Since members are working in a heterogeneous environment, a web portal has been designed to provide a central access point to all relevant information of a particular domain and collaboration platform, including:

- A framework for documents (all common document types),
- Cooperative solutions (forums, subscriptions...),
- Links to community sites (organisation, projects...).

The web portal also provides access to existing documentation and code that members are willing to share. This implies that the structure should provide the means to describe data (notion of metadata) in order to ensure the long-term archiving and the homogeneity of the documents served on the portal.

The solution for the ACT consists of the following modules fulfilling requirements (non exhaustive nor compulsory list):

- Web portal framework,
- Product Data Management solution to provide knowledge repository for documents produced in SARNET context,
- Easy access to scientific,
- Links to community's tools (portals and databases).

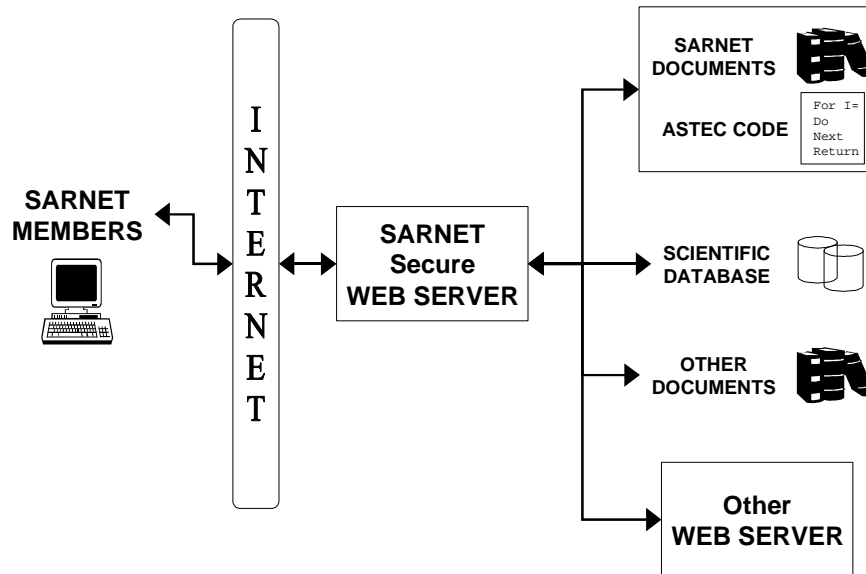

The Web portal framework is the backbone of the community; it provides an integration framework for services, document repository and SARNET codes (mainly ASTEC). This model is in charge of authentication and first discrimination for user access.

The ACT adheres to the model Product Lifecycle Management (PLM) to support the collaborative creation, management, dissemination, and use of information and documents in the ACT from the conceptual phase to end of life, integrating people, processes, and information relating to SARNET.

It provides the following functionalities:

- Document management;
- Support tools for collaboration;
- Support for system administration;
- Code management and versioning support.

The scientific code integration module consists in providing for SARNET partners a simple and easy access to ASTEC code. It first implies for code users access to the reference versions (and tools for delivery and installation), as well as communication between users and the maintenance team (user requests, maintenance answers...). Training support (user's guide, samples...) will be also available to ASTEC code neophytes.

The SARNET Advanced Communication Tool is providing a welcoming access point linked to the existing and future partners portals as well as technical databases. Each partner could ask for integration of links pointing to its own systems and information services whether he considers that it is useful to the community.

GRS is involved in the development/maintenance of this tool; nevertheless most of the SARNET partners are involved in providing feedback and suggestions for improvement.

The development strategy has been based on 3 phases (see below)

Phase 1 : Analysis

Functional Analysis

Technical Analysis

Analysis of existing tools

Definition of the solution

Phase 2 : Development

Prototype development
 Portal module development
 PLM module development
 Integration of links

Phase 3 : Deployment

Deployment on a validation platform
 Deployment

The basic development and deployment of an Advanced Communication Tool (ACT) for the management of information and documents as well as the communication and collaboration of partners in the project was performed in the first 12 months of the project. As a result, a workable platform is now established and in use.

The further work will continue on the topics which have been relevant in the development and deployment of ACT till now:

- Maintenance of the ACT
- Support of the Users
- Evaluation of the feedback from users which may lead to new functionality
- Structuring and mapping knowledge and information content of the ACT
- Extension of the public Internet Web Site.

The maintenance of the ACT is an ongoing work, which concerns the hardware employed, the server and ACT software, and the administration of users and of user's rights, particularly as new users join and old users leave the project. Regular backups will guarantee the function of the portal in case of hardware breakdowns or inadvertent loss of information. In addition, reporting on the use of the portal is needed in order to provide the performance indicators requested to assess the continued growth and use of the portal.

The support of users is an ongoing task, giving help and advice notably to document management issues, setting up new shared spaces, or designing specific sites in the ACT.

User feedback has dropped as the handling of the ACT becomes more familiar to its users. Nevertheless, occasional wishes to extend a feature, e.g. metadata in libraries, have to be taken care of.

First efforts have been undertaken to structure the knowledge and the information accumulated during the project according to its relevance, and to present the main topics of the project, the important documents and the relations to other activities in form of a mapping. This will be useful for dissemination and exploitation of the knowledge gained in the project after the end of the project, and will respond to the Commission's general remark that in the cycle of knowledge production, dissemination and exploitation, the last item is the least developed, particularly after the end of a project. The drafts of knowledge maps which have been created for the ASTEC and the CORIUM topic will be further elaborated, and the other SARNET topics included.

The public Web has to be continuously extended by new information and important documents in parallel to the evolution of the project. In spite of recent efforts, as the current content of this web site is still considered as being rather poor, particular efforts will be continued during the period from April 2007 to September 2008 to update the content and to change the presentation in order to become really attractive.

WP2, 3, 4: Integral Code ASTEC

31 organizations (including IRSN and GRS) have expressed their willingness to collaborate on the adaptation and assessment of the Integral Code ASTEC. This code, which is developed by IRSN and GRS, describes the behaviour of a whole NPP under severe accident conditions. It is extensively used by IRSN for Level 2 PSAs regarding 900 and 1300 MWe Pressurized Reactors. It will serve as the main integrator of knowledge in SARNET and contribute to diffuse it to all members. The ASTEC project is divided into 3 sub-projects, namely:

- Users support/training, model integration and code adaptation,
- Physical model assessment,
- Reactor application and benchmarking.

IRSN and GRS will endeavour, in the limit of their financial capabilities, to offer the support to the users that such a large diffusion will imply.

WP2: Users Support and Training, Integration and Adaptation (USTIA)

The objective of these activities is:

- To distribute the code versions, their updates and their documentation to code users, provide a support and training for code users and organize information exchange between code developers and users (Users Club).
- To integrate knowledge issued from SARNET into the code, adapt ASTEC to all types of water-cooled NPPs operated in Europe.

An IRSN-GRS team will:

- Analyse the requests of ASTEC users and will propose solutions as code adaptation or users recommendations,
- Make the code updates available for SARNET partners,
- Deliver code versions and documentation.

The ASTEC Web site, based on ACT, will be continuously improved and maintained to make easier the exchange of information and documents between the maintenance team and the SARNET users.

All the organizations participating to the ASTEC JPA will participate to the ASTEC Users Clubs. Users Club meetings will be organized periodically (in average once every 15 months) in order to:

- Exchange information on the code use,
- Examine the code status regarding its development and assessment,
- Examine users requests and discuss their priority,
- Prepare recommendations to be addressed to the Governing Board.

Training sessions will be organized upon demand of a significant number of partners. E-learning will be set up on the Web site in order to allow distant training of new users.

In parallel, specifications of developments requested by ASTEC users on one hand to model the different missing systems for SAM and on the other hand to model other NPP types than PWR are being prepared. After JPA3, it appears that almost all needs for VVER-1000 and VVER-440 are now covered by the latest ASTEC V1 versions. Specification work has started for BWR (KTH and IKE, with review by GRS, PSI and IRSN), CANDU (INR and AECL) and RBMK (LEI) and should intensify through detailed specifications during the JPA4, in close links with RAB exploratory calculations. For SAM aspects, only CEA partner is involved about modelling of in-vessel melt retention and external vessel cooling.

WP3: ASTEC physical model assessment (PHYMA)

This activity consists of comparisons between ASTEC and experimental data. In a very few cases, experimental data can be replaced by results provided by detailed reference codes, whose models are

largely more detailed and assessed than the ASTEC ones (example: CFD codes compared to CPA multi-compartment containment part of ASTEC).

This activity will provide inputs for sub-project 1 above, and for the definition of research priorities in the severe accident domain.

In the JPA4 period, the work will consist of:

- First, validation of ASTEC V1.3 versions and its updates, based on the large validation matrix that was defined in JPA1 and possibly the new experimental data produced in the frame of SARNET.
- Secondly, in the last 6 months of the period, a synthesis of the whole ASTEC V1 validation work done during the 4 SARNET periods, possibly implying some verification of improvements of validation on experiments analysed in JPA1 or JPA2.

This activity will be shared between the different organizations, according to their competences and complementarities (19 organizations, including IRSN and GRS, will participate to the short-medium term activity).

The validation will be extended to BWR and CANDU-specific experiments. Five domains will be covered:

- In-vessel phenomena (thermal hydraulic and degradation phenomena): AECL, BNRA, BUTE, CEA, ENEA, FZK, IKE, INR, INRNE, IVS, JRC Petten, LEI, UJV,
- Ex-vessel corium (MCCI, DCH): ARCS, GRS, IRSN, TUS,
- Containment thermal-hydraulic behaviour: ENEA, GRS, IRSN, JRC Petten, JSI,
- Source term: CIEMAT, ENEA, GRS, JRC Petten, JSI, TUS,
- Integral tests (Phébus): IRSN, JRC Petten.

WP4: ASTEC reactor application and benchmarking (RAB)

The objective of this sub-project is to evaluate and improve the capability of ASTEC to simulate reactor transients, including safety systems and main Severe Accident Management (SAM) procedures.

This activity consists of ASTEC reactor applications and benchmarking with other codes. It will provide inputs for the sub-project 1 above, and for the definition of research priority in the severe accident area.

The reactor transients will concern 5 types of reactors: PWR, BWR, VVER, CANDU and RBMK.

ASTEC will mainly be compared to the integral codes MELCOR and MAAP, but also to some specialized codes such as ICARE/CATHARE, ATHLET-CD, SCDAP/RELAP5, COCOSYS, TONUS...

In the JPA4 period, the work will consist in:

- First, benchmarking of ASTEC V1.3 versions and updates, based on the reactor sequence matrix that was defined in JPA1.
- Secondly, in the last 6 months of the period, a synthesis of the whole ASTEC V1 benchmarking work done during the 4 SARNET periods,
- In parallel, periodic update of ASTEC V1 reference input decks for reactor applications (PWR, BWR, VVER, CANDU, RBMK).

This activity will be shared between the different organizations according to their competence and interest in each NPP type (22 organizations, including IRSN and GRS, will participate to the short-medium term programme):

- Western PWR: EdF, EA, ENEA, AREVA-NP SAS, GRS, IRSN, IKE, NRG, TRACTEBEL,

- VVER-440: BUTE, IVS, UJD, VEIKI, VUJE,
- VVER-1000: BNRA, INRNE, KTH, TUS, UJV,
- BWR: KTH,
- CANDU: INR, AECL,
- RBMK: LEI.

WP5: Level 2 PSA

Level 2 PSA is a powerful tool to assess plant specific vulnerability regarding NPP severe accidents. It aims at evaluating possible severe accident scenarios in terms of frequency, loss of containment integrity and radioactive release into the environment. It integrates the results of R&D programmes on physical phenomena involved in severe accidents (experimental programmes and development of computer codes), in a risk assessment perspective. In particular, it makes it possible to quantify the contribution of prevention and mitigation measures in terms of risk reduction.

Different approaches are used in Europe, derived from what has been implemented in the US. The objective of this activity is to compare, to improve and to harmonize the methodologies used for developing Level 2 PSA within European countries and to share effort to develop advanced tools, as far as they are required.

On the other hand, the identification of the most critical difficulties encountered in Level 2 PSA in terms of level of knowledge can contribute to a better prioritisation of R&D activities within the SARNET, in continuation with EURSAFE. Another aspect is the adaptation of methodologies for their application to the reactor types used in the countries which have recently joined the European Union.

Activities have been set up into three sub-projects performed in parallel, each of them involving some active partners.

The programme initially proposed for the first 18-month period was mainly dedicated to the exchange of information, the comparison of partners' approaches and the identification of technical points, where complementary work of common interest is estimated necessary.

During the same period, states of the art have been established on :

- dynamic reliability methods,
- uncertainty and sensitivity methods which could be used in support of PSA level 2.

The programme achieved for the second period (JPA2) consisted in:

- Establishing a more detailed comparison of partners methods for some specific physical phenomena identified as crucial in terms of importance in the level 2 PSA results of lack of importance (leading to major uncertainties),
- Initiating, for those physical phenomena, the improvement and harmonization of methods,
- Comparing the main probabilistic software,
- Establishing a specification of a benchmark exercise to compare the results obtained with classical methods and with dynamic reliability methods,
- Establishing the theoretical basis of the Stimuli Driven Theory of Probabilistic Dynamics.

The programme developed during third period (JPA3) consisted in:

- Proposing first recommendations of harmonized methods on some physical phenomena considered in the level 2 PSA event trees,
- Reviewing the different partners practices as regards use of guidelines in already developed level 2 PSA and establishing the partners views on "possible" and "relevant" themes for harmonization,

- Continuing the efforts on harmonization themes comparing partner's views on large early release definition and on reactor final states for a level 2 PSA, establishing a questionnaire on level 1/level 2 PSA interface,
- Identifying and comparing the different software that may be applied for uncertainty and sensitivity analysis methods which could be used in support of PSA level 2,
- Comparing the results obtained with classical methods and with dynamic reliability methods in the frame of the benchmark exercise,
- Initiating the development of a platform for risk assessment including the development of the SDTPD method.

The programme proposed for JPA4 (12 months) period and for its extension is the direct continuation of the activities performed so far and mainly includes:

- The achievement of the harmonization work started on the different themes,
- The definition of some principles for harmonization on all physical phenomena,
- Setting up a synthesis concerning the use of expert judgments by the different partners as regards state of the art on expert judgment methods,
- As far as possible, the extension to non SARNET partners of the review of practices as regards use of guidelines and views on "possible" and "relevant" themes for guidelines,
- A synthesis of work performed on harmonization aspects (JPA4 extension period),
- The finalization of the deliverable on software for uncertainty and sensitivity analysis methods,
- The specification and achievement of a new phase of the benchmark for comparison of classical and dynamic reliability methods (JPA4), and a synthesis of the conclusions and learning from all phases of the benchmark (JPA4 extension period),
- The continuation of the development of the platform including the development of the SDTPD method (JPA4 and its extension).

Two new tasks will be done in close relation with ASTEC WP and will concern establishing ASTEC requirements for its use for level 2 PSA development and investigations of the possibility of ASTEC coupling with probabilistic codes.

WP 5.1: Comparison of Level 2 PSA approaches and identification of improvement needs

Objective:

The objective is to compare the approaches encountered by the partners in elaborating, quantifying and reviewing existing or ongoing Level 2 PSAs, in order to identify the points related to methods or knowledge which appear to be the most critical and for which improvements are needed. The second main objective is also to propose, as far as possible, ways of harmonization of partners' methods.

Programme:

In the first period of SARNET (JPA1), the different elements of existing Level 2 PSAs amongst partners have been reviewed and compared:

- Level 1 / Level 2 interface,
- Tools,
- Accident progression event tree (structure, events considered),
- Release categories (grouping method),
- Assessment of physical events (general method, quantification of each phenomenon),
- Assessment of systems and human actions,
- Assessment of radiological releases,
- Results in link with R and D priorities,
- General method for evaluating uncertainties (considered in more details in sub-project 2).

These different topics have been discussed, on the basis of papers prepared by the partners. Technical subjects, related to methods or knowledge, where some improvements are considered as necessary, in a risk assessment perspective have been identified. From the list of improvement needs, a first selection has been made for the next SARNET periods.

During the JPA2 period (April 2005 to March 2006), main achievements concerned:

- The synthesis of previous work has been provided (SARNET PSA2-P02 and SARNET PSA2-D36),
- A specific comparison of level 2 PSA for very similar Nuclear Power Plants has been achieved (SARNET PSA2-P09 – VEIKI & UJV),
- Partners methods to take into account hydrogen combustion and immediate consequences of vessel breach have been described in details (most partners),
- A comparison of main probabilistic software has been undertaken (INR).

During the JPA3 period (April 2006 to March 2007), main achievements concerned:

- Proposal of harmonized methods to assess hydrogen combustion, immediate consequences of vessel breach at high or intermediate primary pressure (leading to corium fragmentation and dispersal) has been done (SARNET PSA2-D71 deliverable which has been sent for comments to CORIUM and CONTAINMENT WPs),
- Partners' methods to take into account melt corium and concrete interaction and to assess iodine releases which have been described and compared, first views on possible harmonized methods have been established, nevertheless work is still necessary to define harmonized methods on this subject,
- Definition of large early releases and of reactor final states that may be considered in a level 2 PSA, partner's have provided their own definition and a comparison has been done to derive as far as possible harmonized methods,
- A questionnaire which has been established on level 1/level 2 PSA interface methods,
- A review of main guidelines for level 2 PSA development which has been undertaken,
- Partners' practices concerning the use of guidelines for level 2 PSA development and on themes for which harmonization seems possible and relevant: a questionnaire on has been first prepared, 11 answers have been provided and analysed (SARNET PSA2 D75 deliverable expected to be ready before the end of JPA3 period).

During the JPA4 period (proposal covering the period from April 2007 to September 2008):

- Other SARNET WPs comments on D71 deliverable will eventually lead to a revision of this document (IRSN leader for this task),
- Efforts to propose harmonized methods to take into account MCCI and iodine releases will be continued so that to issue the corresponding deliverable (SARNET PSA2 D72) (NNC, GRS, IRSN leaders for this task),
- Principles of harmonization of the methods to take into account the different physical phenomena will be proposed (deliverable SARNET PSA2 – D100) (IRSN leader for this task).
- Also the deliverable SARNET PSA2 – D99 on definition of large early release and reactor final states will be provided (UJV, VEIKI leaders for this task).
- Harmonized methods will be proposed, as far as possible, for level 1/level 2 PSA interface (Plant Damage States definition, requirements for probabilistic software...) (SARNET PSA2 deliverable) (SWP leader for this task),
- The questionnaire on partners' practices about the use of guidelines for level 2 PSA development and on themes for which harmonization seems possible and relevant has been sent to the participants to the post FISA conference "towards harmonization of level 2 PSA" hold in Luxembourg in March 2006. As far as possible, considering the answers provided, a revision of the SARNET PSA2 D75 deliverable in this subject will be provided (PSI task),
- A short synthesis describing existing guidelines for level 2 PSA development will be provided (ISAR task),
- A synthesis concerning the use of expert judgments by the different partners as regards the state of the art of methods of expert judgment will be provided (JRC task),

- In close relationship with ASTEC WPs, requirements for ASTEC use in a level 2 PSA will be provided (SARNET PSA2 deliverable which also concern WP5.2) (VEIKI leader for this task), crucial point will be to determine relevant “criteria” on different aspects of ASTEC requirements (performance, qualification aspects),
- Also investigations of the possibility of ASTEC coupling with probabilistic codes will be done in a perspective of future benchmark step using ASTEC (see WP 5.3) and of practical and systematic ASTEC applications for level 2 PSA (IRSN leader for this task). Probabilistic software concerned are KANT and EVNTRE, while ASTEC models integration is an intrinsic part of the platform including SDTPD method (see WP 5.3).

WP 5.2: Comparison and improvement of methodologies for assessment of uncertainties

Objective:

From the different improvement needs, the topic concerning the methodologies for the assessment of uncertainties has been initially identified and is treated by the sub-project 2.

The objective of this project is to identify which types of uncertainties have been considered in existing Level 2 PSA amongst the partners, to compare the methods used to assess them and, in a second stage, to improve them and to achieve a certain level of harmonization amongst the partners.

Programme:

The development of Level 2 PSA involves different sources of uncertainties:

- Uncertainties propagated from the Level 1 PSA, related to the frequencies of Level 1 sequences;
- Uncertainties (approximation) due to the binning of Level 1 sequences in Plant Damage States (variables not considered in the interface, values of continuous interface variables);
- Uncertainties (lack of completeness) related to the structure of the Accident Progression Event Tree (events not considered, order and chronology of events);
- Uncertainties (lack of knowledge) related to the probabilities of stochastic events (system failure or recovery, human actions, some physical phenomena such as ignition of hydrogen combustion or triggering of steam explosion);
- Uncertainties (lack of completeness) related to the modelling of physical phenomena;
- Uncertainties (lack of knowledge) related to the values of the parameters of the physical models;
- Uncertainties (approximation) related to the cut-off frequency used in the probabilistic quantification of the Accident Progression Event Tree;
- Uncertainties (approximation) related to the binning of Level 2 sequences in Release Categories (variables non considered, values of continuous variables).

During the first year of SARNET, the different types of uncertainties considered in the Level 2 PSA performed so far by the partners and the methods used to assess them have been identified. Besides, uncertainty and sensitivity methods that could be used in support of PSA level 2 have been reviewed.

During the JPA2 period (April 2005 to March 2006), main activities concerned::

- The synthesis of previous work has been provided (SARNET PSA2-P05 and SARNET PSA2-D37),
- The report concerning uncertainty and sensitivity methods in support of PSA level 2 has been achieved (SARNET PSA2-P06),
- Partners’ methods to take into account uncertainties related to hydrogen combustion and immediate consequences of vessel breach have been described in details (most partners),
- Review of possible software that could be used for uncertainty and sensitivity methods has been initiated (CEA & JRC),
- Besides, according to the recommendations of the EC review of SARNET to “*integrate in the Project the outcome of the Level 2 PSA uncertainties workshop to be organised by the OECD/NEA before the end of 2005, and, if necessary, to reassess the programme in the light of*

these findings”, there was a strong representation of SARNET PSA2 WP members to this workshop (Aix-en Provence – 7 to 9th of November 2005).

During the JPA3 period (from April 2006 to March 2007) main activities concerned:

- The preparation of a proposal of possible harmonized methods to assess uncertainties related to hydrogen combustion and immediate consequences of vessel breach (part of SARNER PSA – D71 deliverable),
- The description of partners’ methods to take into account uncertainties in melt corium and concrete interaction and to assess uncertainties in iodine release and proposing possible harmonized methods on this subject (task to be achieved during JPA4),
- The review of possible software that could be used for uncertainty and sensitivity methods has been continued (task on going to be ended during JPA4 period).

The proposal for JPA4 period (proposal covering the period from April 2007 to September 2008) is associated with proposal for WP5.1 and consists in:

- The achievement of the deliverable SARNET PSA2 D72 (part of the document related to methods to take into account uncertainty on iodine release and on MCCI) (IRSN, NNC, GRS leaders for this task),
- The achievement of the SARNET PSA2 – D101 deliverable (review of tools for uncertainty and sensitivity analysis methods in support to level 2 PSA development with description of the different tools functionalities) (CEA task),
- The description of methods to take into account cliff-edge effects (CEA, ISAR tasks).

WP 5.3: Improvement of event tree methodology using dynamic reliability techniques

Objective:

From the different improvement needs, the development of dynamic reliability method has been initially identified and is treated by WP 5.3.

The event tree technique has been developed mainly to represent different scenarios of accidents, influenced by functional events. It has been used first in Level 1 PSA and extended to Level 2 PSA. A specific feature of Level 2 PSA event trees is that physical variables have to be assessed along each branch of the event tree, in order to identify the mode of loss of integrity of the containment and the radioactive release into the environment. Therefore a strong coupling exists between stochastic functional aspects and deterministic (but uncertain) physical aspects of the accidents, which are difficult to take into account within the classical event tree methodology.

The general objective of this sub-project is to study how the techniques of dynamic reliability could be used in order to improve the event tree approach in Level 2 PSA.

When specifying a possible approach, one should consider the assessment of uncertainties in particular those related to physical phenomena. Moreover, the complementary techniques making it possible to reduce the number of calculations, as importance sampling in Monte-Carlo approach, should be considered.

Programme:

Dynamic reliability techniques have been developed in order to study the reliability or the availability of continuous processes evolving with time in interaction with functional processes. Examples of such techniques are Petri nets, Discrete Dynamic Event Tree (DDET), Monte-Carlo techniques or combinations of the previous ones.

Before SARNET, some works on (Level 1 or Level 2) PSA have been already performed, in particular by GRS (Germany) and CSN (Spain) in collaboration with the University of Brussels.

During the first SARNET period, the current limitations of the classical event tree approach have been identified and the concepts and the state of the art of the dynamic reliability methods have been drawn up (SARNET PSA2 – P04). A description of the SDTPD method (Stimuli Driven Theory of Probabilistic Dynamics) and an example of application of the MCDET (Monte Carlo Dynamic Event Tree) for induced breaks on the reactor coolant system have been also provided.

During the SARNET JPA2 period (April 2005 to end of March 2006) following tasks have been achieved:

- The comparison of the MCDET method results with classical methods results on the example of station black out situation (GRS),
- The synthesis of previous work (SARNET PSA2- D38),
- Another relevant example for dynamic reliability application has been chosen and a draft of specification for a benchmark exercise for application of dynamic reliability methods in comparison to classical methods has been prepared (IRSN); the benchmark exercise so selected concerns the risk of containment failure due to hydrogen combustion. Events that could influence the risk are the core reflooding and the spray system operating (that could intervene at any time), and hydrogen ignition due to recombiners effect or to any other random source of ignition (SARNET PSA2 - P12),
- Development of SDTPD theory has been continued in the perspective of both the benchmark exercise and more global applications (CSN & ULB).

During the JPA3 period (April 2006 to March 2007), following tasks have been achieved:

- The two phases of the benchmark exercise have been achieved (first without considering uncertainties and then considering uncertainties (participants were AREVA, CEA, GRS, INR, IRSN, LEI, UJV, ULB, VEIKI) and the corresponding deliverables (SARNET PSA2 – D97) will be provided in April 2007,
- A statistical exploitation of the results obtained with the SDPTD method has been done by LEI and will be provided early during JPA4 period,
- The development of the SDTPD theory has been continued in the perspective of more global applications and considering possible ASTEC “coupling” (including necessary software development in the frame of the RISK TEC platform). The sequence algorithm has been developed and applied to the benchmark exercise, one mobility programme has been proposed and accepted on this subject,
- A second mobility programme has been proposed and accepted on the use of the Monte Carlo method in the frame of dynamic reliability problems.

During the JPA4 period (proposal covering the period from April 2007 to September 2008):

- The specification of the benchmark exercise on hydrogen combustion issue for comparison of classical and dynamic reliability methods will be revised to include a third step (CSN, ULB, IRSN leaders for this task). The modifications will concern:
 - o The separation of epistemic and stochastic uncertainties (to be quantified separately),
 - o The introduction of delays in human actions achievements (core reflooding, spray system operating) so that the exercise be more realistic and also to enhance the possible advantages of the SDTPD method,
 - o Better modelling of steam condensation.
- The achievement of the step 3 of the benchmark (same participants expected than for earlier steps) and a final conclusion of the benchmark including perspectives of dynamic reliability methods use (SARNET PSA2 deliverable),
- In parallel, the continuation of the development of the platform including the development of the SDTPD method (SARNET PSA2 - D102 deliverable in October 2007, then second deliverable in October 2008 on conclusions on SDTPD methods development and possible uses)

Implementation of scientific databases

The objective is to develop and maintain an instrument that insures preservation, easy access for codes, exchange and processing of severe accident experimental data, including all related documentation.

The data of concern are:

- Existing experimental data that SARNET partners are willing to share with the other partners in the network;
- All new data produced within SARNET.

No European database existed to host severe accident data in a unified platform for long term storage, sharing and use. A first step towards the development of such a platform was undertaken in WP5 of the EURSAFE project (5th FWP). A platform mock-up has been developed in EURSAFE starting from the STRESA structure. Basically, a web connection to a portal hosted by one of the partners (database net administrator) gives access to local servers (nodes) hosted by the other partners. In general, each local server contains the data of the partner who hosts it, but a more centralised storage can be envisaged whenever necessary. A STRESA software is installed on each local server, which is managed by the partner himself who decides and controls access to his data through different authorisation levels as a function of the property rights.

This system is a good candidate to become the SARNET experimental database. The action is carried out in 3 phases:

Phase 1: Evaluation and decision (achieved during SARNET first year)

Partners that already were trained to the use of STRESA have assessed the platform. Recommendations to select STRESA have been confirmed.

Phase 2: Deployment (achieved during the SARNET first three years)

The software will be distributed and implanted on sites of new users. Training sessions will be organised.

Phase 3: Data storing and platform maintenance (phase still going on)

In the continuation of EURSAFE experimental database work-package, some data storage was already foreseen by some partners since the beginning of the contract:

- Data from PLINIUS platform: VULCANO, COLIMA;
- Data from Phébus FP and VERCORS;
- Data from KJET, PREMIX, ECO, QUEOS, DISCO;
- Data from FOREVER, KMFCI, POMECCO;
- Data from CODEX-VVER: core degradation bundle tests;
- Data from VICTORIA and HORIZON.

Beyond this, data produced in SARNET will be integrated to the platform as they become available.

In parallel the developer of the platform will support the users and up-date the software in the frame of so-called maintenance activity.

This platform has been linked to the SARNET Advanced Communication Tool.

Research priority assessment

The objectives of this action are to provide the Governing Board of SARNET with guidelines for defining the orientations to give to the JPA in terms of joint research activities of common interest and high priority, to reassess the research priorities for the different issues set up by EURSAFE under the

aspects of SARNET, to include in the orientation process the safety significance, risk potential and knowledge on the different phenomena. This action will make use notably of:

- The outcome of the EURSAFE action (results of PIRT on severe accidents);
- The results of the qualification/benchmarking activities on ASTEC;
- The results of reactor calculations carried out in the other activities;
- The outcome of the research performed in the three thematic sub domains of SARNET (corium, containment, source term);

It will make use also of results obtained in the frame of other international projects (ISTC, OECD...). The outcome of Level 2 PSA activities, carried out in the frame of national programmes, will be regarded in particular in the assessment of the priorities (risk-informed research as it was stated by the former EU project VASA). It will take into account the potential capabilities of SARNET and identify the potential experimental or theoretical programmes to undertake for resolving the identified important pending issues.

The ongoing action is performed by 12 participants in close collaboration, representing TSO, industry and utilities. This collaboration between the experts who perform research and the ones who use its results is essential to correctly address the phenomena and its relevance. A stronger involvement of PSA Level 2 specialists was started to input PSA level 2 results for better estimation of the impact of risk on the relevance of the discussed phenomena.

The action will result in a ranking and will allow in fact determining which programme should be initiated or pursued and which should be closed or not started. To follow as well proposals made in the frame of OECD-CSNI working groups, the criteria for ranking will reflect considerations such as:

- the priority of the safety research issue it entails,
- the capacity to address a safety issue in a comprehensive manner,
- the potential for substantial improvements in accident mitigation and management procedures,
- the level of risk involved (when risk assessment is feasible and/or appropriate),
- the extend to which it affect plant operation, if it is an operating plant issue,
- the number of plants affected (if it is only a unique plant type),
- the likelihood it will bring conclusive results,
- the programme cost and duration,
- the relevance for maintaining strategic competence and infrastructure.

There are conditions under which closing an issue becomes a necessity; nevertheless, defining generic closure criteria is very difficult. The following principle might be used, and a research issue could be proposed for closure, when there:

- is convincing information available that the issue addressed does not constitute a challenge to safety plant,
- is a general understanding that knowledge is adequate and further research is not needed;
- it is unlikely that further research will provide end users with results that will increase significantly the knowledge that is already available (for instance because the return of knowledge from a programme diminished substantially with the time);
- are important changes in the situation (e.g. in industry plans or in regulator priorities), which reduce the overall priorities of a research item.

Since closing an issue and the related programmes may lead to teams of experts to be disbanded or facilities closing, it will be important to weight carefully the consequences, and examine which re-orientation might be proposed in order to avoid irreversible loss of strategic competence and infrastructures.

The results of this action will be distributed to all participants for comment before their release. They will be transmitted to the scientific coordinators coordinating corium, containment and source term

activities, for taking into account in the elaboration of their work proposals. In the process of defining the orientation for joint research activities of common interest and high priority it will be tried to address the expected benefit and the work to be performed and its associated schedule for the research items.

Integration assessment

This action consists of the evaluation of progress made by the consortium towards its objectives, and of the definition of corrective actions where necessary.

The members of the management team carry out the action. It consists of:

- collection of information necessary to measure the evolution of progress indicators as defined in Chapter 4 (quality of integration, indicators),
- analysis of the results (explanation of indicator evolution, definition of the progress margins),
- proposal of actions (revision of the JPA, proposal of contractor actions beyond the JPA, ...).

A yearly report on these indicators is released. Furthermore, after two years of SARNET, it appeared that some of the progress indicators were poorly adapted, so further reflexion will lead to modify some of them.

3.2.2 Programme for Jointly executed Research Activities (JPA/JRA)

The EURSAFE project highlighted a number of remaining important safety issues, which need to be investigated experimentally. The critical mass of competence (experimental facilities, experts) necessary to address these issues was identified. This competence has been assembled in the SARNET network with part of their current activities, as far as these activities have a link with the issues to be investigated. This assembly constitutes a promising matter of tight cooperation between participants of SARNET.

The Joint Research Activities programme, which is presented hereafter, is an added element aiming at promoting in sustainable way collaboration within the above assembly, between the main European actors in nuclear safety. The basic elements for such a promotion are:

- reaching a common understanding of issues and phenomena, of their importance in terms of safety and knowledge,
- determining a consensual approach to resolve the remaining uncertainties.

Thus, the JRA consist of:

- The joint elaboration of syntheses on the interpretation of experimental results and joint elaboration of recommendations for model implementation in ASTEC;
- The joint elaboration of programme proposals; these proposals will address underway programmes (recommendations, re-orientation, ...) but also new ones; these proposals will take into account as an input conclusions released by the so-called "research priority assessment";
- The joint elaboration of work plans aiming at making the best of available competences and means, and their monitoring.

The JRA are clearly linked to the associated activities described in §3.2.1. Indeed, their results, aiming at solving Corium, Containment and Source Term issues, are the basic inputs of the JPA.

The experts of the network jointly analyse and discuss on experimental programmes performed within national programmes activities. They jointly formulate recommendations on test matrix, on test procedures or on instrumentation (practically partners involved in these experimental programmes will provide these experts with information on facility description, facility capabilities and

limitations...). After a first period of work and according to the remaining issues, if new data are required, the experts will have to formulate recommendations on test definition.

Experts have also joint interpretation activities, which consist in analysing the different interpretation works performed within the associated programmes. From the discussions, analyses and comparison work, only possible in such a network frame, a better understanding of physical phenomena is expected. This activity constitutes a feedback for the orientations of the experimental programmes, and is a really integrating activity for sharing in the European Union the knowledge obtained through the interpretation of experimental results.

A similar activity has been undertaken for joint modelling, that is to say that experts in the frame of JPA will analyse, discuss and compare their approach. Such activity has the objective to converge on recommendation on the development of a model. The final outcome is to make recommendation for models implementation in ASTEC.

All the associated experimental programmes are part of the so-called Pre-Existing Know-How (PEKH). The corresponding access rights will be granted following principles defined in the Consortium Agreement:

- the access rights to pre-existing know-how (when not declared as non available) will be granted on a royalty-free basis for carrying work under the JPA;
- the access rights to “protected” data will have to be negotiated.

Thus, when elaborating the JPA, the access rights limitations are identified in order to make possible in a deadline consistent with the timetable the completion of the negotiation.

The results of interpretation of non-European experimental programmes, performed in the frame of for instance OECD or ISTC projects, will be used as inputs of the JRA.

In the particular case of ISTCs (those lying in the domain of interest of SARNET and monitored by CEG-SAM), specific actions will be defined and carried out inside the JPA, and aiming at:

- orientate the corresponding research programmes,
- monitor the progress,
- and carry on the interpretation of experimental results.

These actions will lead, at least from a technical point of view, to a partial integration of ISTC in SARNET.

On practical way, the experimental results used in the frame of the project are collected and documented in the SARNET experimental database to be shared easily (with all the guarantee concerning the access rights). Thus, as far as possible, the data implementation in the experimental data base is planned consistently with needs of the JRA.

Expert meetings are periodically organised. We can distinguish 2 kinds of meeting:

- The yearly review meeting (one per domain) to present synthesis of the work performed and to discuss for the concerned domain the orientations of the next JPA period;
- Specialized meetings (with no precise frequency), involving a small number of experts and devoted to technical points which could cover a work package or a part of it.

Resolution of corium issues

21 organizations participate to this topic; three work-packages have been defined:

- WP9 Early phase core degradation (EARLY)
- WP10 Late-phase Core Degradation and Vessel behaviour (LATVES)

- WP11 Ex-vessel Core Recovery (EXCORE) dealing with MCCI and Debris Coolability.

WP9 addresses the risk of early containment failure, due to rapid generation of hydrogen, which may not be accommodated by re-combiners. It deals with hydrogen generation during core reflooding conditions (esp. oxidation of metal-rich mixtures), B₄C and fuel burn-up impact on core degradation, and more generally the remaining questions in the core degradation early-phase (in particular, oxidation of clad with advanced alloys and hydrogen generation during melt relocation into water present in the vessel lower plenum). It considers various atmospheres including air and air/steam mixture as they have a strong impact on fuel behaviour and fission product release. Experts will continue to review experiments such as BECARRE, CODEX, MOZART, PARAMETER, QUENCH experiments, as well as Phébus FPT2, FPT3 and CORA-13 and 28 reactor tests, and jointly propose recommendations on tests design and tests matrix. Interpretations based on main codes calculations (ICARE/CATHARE, ATHLET-CD, MELCOR, SCDAP, MAAP4,...), performed by SARNET partners, will be analysed and compared, with the objective to produce a synthesis on joint interpretation of experiments. Proposals of models from partners will also be studied and debated, leading to a synthesis on modelling and to proposals for ASTEC.

From experimental point of view the next period highlights will consist of:

- QUENCH experiments: QUENCH-13 with SIC control rods,
- Separate effect tests on the oxidation behaviour of new cladding materials in steam and air,
- Continuation of B₄C experiments (BECARRE Parts II and III) on the MAESTRO platform facilities at IRSN,
- Small scale tests on air ingress at IRSN, INR and FZK.

Close link will be maintained with PARAMETER and VVER QUENCH in the frame of ISTC through exchange and recommendation against CEG-SAM group of expert.

WP9 partners will continue their interpretation activities around available results to improve oxidation and degradation modelling and to provide as a final objective new models or correlations for ASTEC.

In term of networking a strengthening of the joint activity has been achieved through pre and post calculations of QUENCH tests by several institutes. ERMSAR papers will synthesize the results of these joint activities.

WP10 is devoted to late-phase degradation and corium behaviour in lower head, with the objective to improve predictability of the thermal loadings on RPV lower head. After review of main experiments (SIMECO, LIVE, MASCA, DEFOR, MISTEE-J...) joint recommendations on these experiments (test specifications,..) will be drawn according to remaining issues on corium pool configurations. As for WP9, experts will also have to study the different interpretations produced by partners on these experimental results, and associated modelling proposals. Syntheses are planned to be issued and proposals for ASTEC models improvements will be done.

The experimental program in the LIVE facility (study of lower head pools) will continue at FZK with pre and post test calculation support from IKE, CEA and potentially KTH.

KTH has designed new experimental program during the second period devoted to the debris coolability. A new facility DEFOR is devoted to study the debris formation mechanism that impacts the size, the shape and the 2D settling of debris. It will complete MISTEE-J facility devoted to jet break-up and POMECCO-U devoted to debris coolability. Bed Formation tests are planned during the coming period.

After the building of a new facility by CEA and TECHNICATOME to study external vessel cooling and validate the concept retained for experimental low power reactor, the first tests are expected in 2007.

WP10 partners will continue their interpretation activities around available results to improve progressively and according to the most safety relevant issues degradation, relocation, debris formation, debris coolability, corium pool behaviour and vessel behaviour including external cooling models. This activity will contribute to the improvement of several simulation tools but with a final objective that is to provide new models or correlations for ASTEC.

In term of networking a strengthening of the joint activity is expected by the promotion of several benchmark exercises. In the frame of WP10, the second subject concerns the thermo-mechanical vessel behaviour. A new benchmark exercise, yet to be finalized will pursue the integrating activities that went with last years OLHF benchmark. Several partners will contribute also during the coming period to OECD TMI2 reactor benchmark and transpose to reactor case the models gained during the joint R&D.

Activities of **WP11** should improve the predictability of axial versus radial ablation up to late MCCI phase for homogeneous and stratified corium pool, in order to determine basemat failure time and loss of containment integrity.

Ex-vessel case with water injection will be also part of the activities of this work-package: an increase of knowledge of cooling mechanisms is expected, in view of being able to demonstrate termination of accident progression. In particular, ex-vessel particulate debris coolability will be investigated in relation also with in-vessel.

Main experiments on debris coolability (DEBRIS, STYX, POMECO-U, DEFOR, VULCANO-COMET....) and on MCCI (MCCI-OCDE, VULCANO, COMET-L...) will be analysed. Experts will analyse the interpretation works, and jointly produce a synthesis. At final stage a common proposal of models of corium concrete or ceramic interaction and corium debris or melt coolability will be formulated for implementation into ASTEC.

It must be noted that multidimensional effects have been found during the first years of SARNET to affect largely both debris bed and MCCI issues. They will be studied in detail in the coming period.

For the fourth period and from experimental point of view we have the following items:

- KTH has designed, during the second period, a new experimental program devoted to the debris coolability. The new MISTEE-J and DEFOR facilities will be devoted respectively to the study of jet break-up and debris formation. They will complete POMECO-U facility devoted to debris coolability.
- After the completion of three corium-concrete interaction VULCANO tests with oxides only, CEA has started a tests campaign with oxides and metallic phases in 2006. In a complementary way with OECD MCCI-phase 2 program, analysis of stratified configurations will continue. In particular, the post test examination of the first test shall provide data necessary to interpret the unexpectedly large oxidation of the metallic layer.
- In simulant fluid, the 2D ARTEMIS program will be continued during the fourth period. It should also be next extended also to stratified configurations.
- IRSN is planning a new experiment on 2D debris bed quenching and partners may provide comments and contributions to its design.

WP11 partners will continue their interpretation activities around available results to improve their understanding of:

- corium concrete ablation mechanism to explain the difference in term of radial and axial ablation as a function of the concrete composition, looking both heat transfer sources of heterogeneity and differences that may appear at interfaces between corium and concrete,
- debris formation, 2D settling and accumulation mechanism in connection with debris coolability issues (friction law, pressure drops, 2D effect regarding counter-current flow limitation...),

- corium coolability in core catcher (COMET core catcher concept, downcomers; spreading issues for EPR core-catcher modelling),
- corium coolability for top water injection situation in connection with OECD past and foreseen tests and CEA past test (PERCOLA).

These activities will contribute to the improvement of several simulation tools, with a final objective that is to provide new models or correlations for ASTEC. In particular, a joint action has been launched to reach a consensus on a simplified corium spreading model for ASTEC. This consensus will be based on the performance of a benchmark, coordinated by CEA, on reactor applications between simplified and mechanistic models.

In term of networking a strengthening of the joint activity is expected by the promotion of several benchmark exercises. In the frame of WP11, the main subject concerns corium concrete interaction in homogeneous and stratified pool configuration with a benchmark exercise on a typical reactor case.

As subtopic coordinator, IKE proposes to have joint elaboration about boiling mode (adequate model of friction laws, effect of debris shape and size) and about quenching mode for top or bottom cooling conditions (1D/2D quenching front progression) through joint interpretation of available experiments (DEBRIS, STYX, COMECO, SYLPHIDE...) or definition of new test matrixes.

The code WABE developed by IKE has been provided to KTH and VTT. Use of a common tool by three institutes will also be an integrating process in the coming year.

In term of networking, improvements are still expected to make our activity more visible and extend the sharing of information within the entire work package. The sharing of the coordination activity at subtopic level (IKE for WP11.1 and CEA for WP11.2 and 11.3) improves technical exchanges and will contribute to make them more visible by an extensive use of ACT capabilities (discussion forum, online document elaboration and sharing, technical meeting preparation...).

Remarks on the resolution of the Corium Issues

1/ Thermodynamic and thermo-physical databases

Among the different contributions, the experts on thermodynamic or thermo-physical properties are not merged into a specific work-package. They have to play a role in every WP and in every task. Through their participation in these joint activities, they will access to a large experimental database and contribute actively to definition, interpretation or modelling tasks. A part of WP outcomes will contribute to the assessment and development of databases (NUCLEA¹ for Thermodynamic properties and CORPRO for Thermo-physic properties), which contribute to the development of the Material Data Bank of the ASTEC code. Moreover, if some data significant for a given phenomenon are missing specific orientation of existing experimental programs or specific programs may be defined in the frame of the related work-package.

AECL will enlarge the SARNET thermophysical knowledge by contributing a report on CANDU-related physical properties.

2/ Trans-national access platforms

In the frame of this project, one trans-national access platform may be included: the PLINIUS FP6 platform. Although outside SARNET network, it is linked by the participation of a SARNET representative to the Selection Panel. In the future we can imagine a joint steering of experiments performed on such a platform taking into account also the needs expressed for SARNET research and training activities. This will need to define in the frame of the elaboration of a "post contract

¹NUCLEA thermodynamic properties database is a commercial pre-existing know how excluded from SARNET project. It is necessary to buy the database to use it.

Consortium Agreement” the mechanisms, which could make possible a common funding. It is expected that a follow-up of the LACOMERA contract will be proposed to the EC.

3/ Link with ISTC and OECD

Some non-European R&D programmes, performed in the frame of OECD and ISTC projects, will provide additional inputs for the SARNET work on corium issues: MASCA, CORTRAN, ISTC-INVECOR, ISTC-2936 Core melting (corium molten pool behaviour), OLHF (vessel failure), ISTC-1648.2 and PARAMETER (core quenching), ISTC-METCOR.2 and ISTC-CORPHAD.2 on corium interactions and properties, ISTC CHESS project on Chernobyl corium data and calculations and OECD-MCCI phases 1 and 2 on molten corium-concrete interactions.

During the last CEG-SAM meeting a more intensive information exchange between ISTC and SARNET has been discussed and recommended. For new proposal or proposal update, the Corium coordinator will receive information and organise a consultation among Corium topic members to obtain technical advices and declaration of interests. Consultation results will be transmitted to the CEG-SAM secretary.

4/ ERMSAR Conference

The Corium topic will contribute to 6 lectures in the coming ERMSAR conference: one general presentation of the joint activities devoted to corium, and presentations of the QUENCH-11, OLHF, COMET L2-L3 benchmark exercises, of the clad oxidation by air activities and of the preliminary joint analysis of Phébus FPT3. An invited lecture on the OECD-MCCI project will emphasize the links between these two projects.

5/ Future activities

Meetings are planned to reach a consensus on the possible work that may remain necessary on the Corium issues after the completion of the current SARNET project. This task will be conducted in close collaboration with SARP WP.

Resolution of containment issues

The research efforts concentrate on 2 work-packages, involving in overall 21 organizations:

- WP12: Investigation of Hydrogen Behaviour in Containment (HBC),
- WP13: Investigation of Fast Interactions in Containment (FIC).

Within WP12, partners are studying the containment atmosphere mixing phenomena, and hydrogen combustion and associated risk mitigation. Experimental activities carried out in national programmes are discussed by experts, and recommendations for the tests specifications of ENACCEF, REKO-3, TOSQAN and MISTRA or other facilities are formulated. Interpretations based on CFD codes (TONUS, REACFLOW, GASFLOW, commercial codes) and Lumped Parameter codes such as COCOSYS, ASTEC or TONUS-0D and other codes, performed by partners, are discussed, in order to propose improvements in modelling capabilities. Analytical or code-to-code benchmarks are proposed in the framework of inhomogeneous hydrogen mixtures, wall condensation, spray system and interaction between recombiners and containment atmosphere. From this work, experts will produce syntheses, showing the progress on common understanding of these issues.

WP13 is dedicated to activities concerning the Fuel Coolant Interactions (FCI) and Direct Containment Heating (DCH) phenomena. Numerous experiments such as FARO and ECO for FCI issue, and DISCO for DCH, are reviewed by experts with the objective to make common proposals to better address these issues. For FCI this has resulted in a common proposal for a second phase of the OECD/SERENA program. Interpretation of these experiments, with existing models and CFD-codes such as MC3D or MATTINA, respectively AFDM, has been analysed by experts with the objective to reach a consensus on these interpretations. Synthesis reports are being prepared. The possibility to link FCI stand-alone codes with ASTEC calculations is under consideration. Benchmark calculations

of DCH experiments are performed with MAAP, CONTAIN and ASTEC with the objective to find models most qualified for ASTEC modules.

Resolution of Source Term issues

Twenty-three organisations cooperate in performing research in the Source Term domain. Research activities in this area are organized into 3 work-packages:

- WP14: Investigation of FP Release and Transport phenomena (FPRT);
- WP15: Aerosol Behaviour impact on Source Term (AEROB);
- WP16: Containment Chemistry Impact on Source Term (CONTCHEM).

WP14 activities improve the knowledge related to FP release and transport. Activities both address the impact of air ingress in a reactor core on source term and the iodine speciation along its transport in the primary circuit. Experiments such as VERDON, VERCORS, MERARG, VTT speciation tests and RUSSET for air ingress/ruthenium release and transport effects, and CHIP for iodine speciation are reviewed by experts and common proposals and comments are addressed to either re-orient some tests or to propose new ones. New partners AECL are making their data available, while VTT are starting new revaporisation/speciation experiments with a more general focus. Interpretation work carried out by partners on these experimental results is analysed, with the objective of delivering a joint synthesis. Experts apply the same approach for the modelling proposals. Concerning the air ingress issue, reactor transients simulated by partners with different integral codes such as ASTEC, SATURNE/MAAP, SCDAP/RELAP5 and ICARE/CATHARE are compared and analysed to determine the impact of remaining uncertainties and to define conditions for the separate-effects tests. Analysis of silver-indium-cadmium rod degradation and structural material release data such as those from EMAIC will also be pursued, given the importance of these elements in influencing the iodine source in the circuit. Active support will be given to the PWR experiment QUENCH-13 at FZK, whose results should help in refining estimates of Ag, In and Cd release from the core.

WP15 should reduce uncertainties on the quantification of source term for aerosol retention in the secondary side of Steam Generators, remobilisation of deposits through revaporisation and resuspension and leakages through cracks in containment walls. Experiments such as ARTIST, PSAERO/HORIZON, PECA/SGTR, STORM, REVAP, RADSOL, RECI and SIMIBE are analysed by experts, as well as related interpretation work and modelling proposals. A joint synthesis on interpretation and modelling should be issued from the experts' work.

Iodine source term is the main issue considered in WP16. Specific experiments such as EPICUR, PARIS, ThAI-Iod9, CAIMAN and Chalmers tests are studied and common recommendations on test specifications, or programme re-orientation will be given by experts. In particular, a benchmark exercise is being performed on the basis of the integral test ThAI-Iod9. Experts will also concentrate on analysis of the interpretation work and associated modelling proposals on iodine behaviour under severe accident conditions in the reactor containment. This is supplemented by similar work on ruthenium matters (IRSN tests), and on the effect of fission product heat-up on passive autocatalytic recombiners (RECI programme and possible successors). An iodine data manual, collecting numerous experimental data and reviewing models, is in an advanced state of preparation. A synthesis will be produced taking account of interpretation of experimental results, and suitable modelling, representative of a common understanding of the phenomena. In addition, larger-scale experiments like Phebus-FPT2 will be simulated so that it will be feasible to assess model predictability.

3.2.3 Activities designed to spread excellence

The excellence spreading activities consist of 3 elements:

- WP17: Education and Training;
- WP18: Book on Severe Accident Phenomenology;
- WP19: Mobility programme.

Its objectives are to:

- Enhance and maintain competence in Severe Accident Research (SAR), contributing to Severe Accident Management (SAM) through education and training of students and young researchers in Europe;
- Impart additional skills to the researchers and analysts in the severe accident risk assessment;
- Foster integration of national programmes through sharing of researchers and work programmes.

The approach followed to achieve the above objectives will be to:

- Develop educational forums e.g. yearly courses, lecture notes, etc.;
- Develop training forums e.g. courses for nuclear safety specialists, etc.;
- Promote personnel mobility between the various European institutions;
- Develop user groups for important computer codes e.g. ASTEC;
- Integrate with other education and training work programmes in other networks;
- Develop links with the European Nuclear Education Network (ENEN).
- Draft a comprehensive (about 400 pages) text book on “LWR Severe Accident Safety”

More precisely, and for the period from April 2007 to September 2008:

The various activities in the **education** element, targeted at Ph. D. students and young researchers will aim at providing one or two courses among the following ones:

- Course on Severe Accident Analysis and Management;
- Course on Level – 2 PSA, with description of codes (mainly ASTEC), for consequence analysis;
- Interface with a course developed by ENEN on Nuclear Power Safety, including an introduction to the Severe Accidents and to Level – 2 PSA.

Following the first session of the course on severe accident progression (analysis, data and uncertainties) on PWR and BWR reactors, held in Cadarache in March 2007, the **training** element, targeted at specialists of nuclear safety, will aim to provide a second session of this course, more oriented to VVVER and CANDU reactors (no precise date can be given yet).

The Book element activities will consist in:

- writing “Lecture Notes on Severe Accident Phenomenology” based on the text material that was compiled for the SA Phenomenology Course given in Cadarache in January 2006;
- progressing on the comprehensive (about 400 pages) text book on “LWR Severe Accident Safety”, with the aim to issue it in a final form early 2008.

The mobility element involves masters and Ph.D. students, and researchers. This element is of great importance towards the integration of the European National Programmes in Severe Accidents and in the Probabilistic Safety (Risk) Analysis. Clearly, the mobility programme of SARNET requires adequate funding for exploiting the long-term integration possibilities offered by the personnel mobility. The joint activities pursued in this programme element consist in:

- Providing internships for students;
- Developing a programme of deputing researchers at the facilities of different partners for periods up to one year.

Practically speaking, for the period from April 2007 to September 2008, the number of mobilities, should be comparable to the one of SARNET year 3. About twelve mobilities are expected through a strong involvement and coordination work (e.g., using the internal SARNET website, ACT) by the Excellence Spreading Topical Leader.

The partners who have agreed to work together in making a success of the integration process that will be brought about in the Education and Training sub domain of the SARNET JPA are universities,

Technical Support Organizations (TSOs), national laboratories and industrial organizations. They bring enormous talent and experience to the joint programme. They also have the young as well as the more experienced personnel to make education and training a jointly beneficial activity. There are professors from universities who are internationally recognized and who love to teach and there are researchers from national laboratories whose research achievements are well documented. There are participants from the recently-joined Eastern European Countries who will not only bring the knowledge base needed to deal with the Soviet-designed reactors, but also bring the rigor of education that is practiced in Eastern Europe. The recently joined Eastern European Countries also have relatively larger number of young persons enrolled in nuclear engineering profession as students and researchers. They would increase the pool of the future competent persons that are needed for the welfare of the nuclear industry in the whole European Union. We believe that we have assembled a great team of participants for the Excellence Spreading JPA.

Finally, during the period from April 2007 to September 2008, it is aimed to “spread excellence” via communication to other stakeholders (e.g., utilities, regulators, interested public organizations, etc.), by using the Internet (e.g., SARNET public web site), brochures and information letters and through public forums.

3.2.4 Management activities

These activities mainly consist of:

- General coordination of the JPA;
- Financial coordination;
- Reporting;
- Diffusing information.

The technical coordination (knowledge generation, knowledge preservation and identification of needs in knowledge) more precisely consist in:

- Monitoring progresses;
- Checking release of deliverables in due time;
- Surveying milestones;
- Organizing technical reviews when necessary;
- Anticipating difficulties in carrying out the JPA and taking appropriate actions to overcome them;
- Making a synthesis of all recommendations coming from current projects for updating yearly the JPA;
- Managing the information system and making sure that access rights are fully respected;
- Implementing the decisions of the Governing Board.

The financial coordination consists in:

- Elaborating estimated budget for coming year;
- Monitoring expenses, in particular those partly or totally covered by the Community funds;
- Allocating Community funds in accordance with the Contract conditions, the Consortium agreement provisions and the decisions of the Governing Board;
- Establishing yearly cost statements for all the expenses of the JPA and funds allocated.

The Management Team yearly reports to the Commission and the Governing Board on the technical progress made in the JPA and on the financial status. It organizes the meetings (preparation, minutes) of the Governing Board, of the Advisory Committee and of the Ad-hoc Scientific Review Committee.

A large part of the management activities is also devoted to the dissemination of information and Knowledge inside and outside of the Network (link with the Excellence Spreading activities):

- Information on the progress made in the JPA;
- Information on main outcomes of the JPA;

- Information exchange between participants on their activities and specificities;
- Promotion of joint publications in open literature;
- Organization of annual conferences and topical seminars.

Beyond these tasks a large effort has been initiated since July 2006 to revise the Consortium Agreement in order to define the conditions, which will make possible the prolongation of the network after completion of the current contract with the European Commission.

3.3 Plan for using and disseminating knowledge

As the main obstacle to integration of most of the experimental programmes is the need to raise funding at national and extra-national levels. A clear policy in terms of knowledge management, notably regarding access rights to experimental data produced within the network, is proposed to preserve the interests of the different organizations. For instance, data reports on “protected” experimental programmes are only distributed to those members who need them to perform their part of the Joint Programme of Activities. Generally speaking, these members are already partners as co-funders in these programmes. In addition, it is planned to issue progress reports on these “protected” programmes, so as to provide any member with the opportunity to negotiate with the owners of these programmes the access to the data to participate to the joint research activities around them, or to use the knowledge in application of SARNET; more, the Consortium members committed to grant the access rights for use outside of SARNET on fair and non-discriminatory conditions. In any case, the outcomes of these programmes are models to be implemented in ASTEC or in qualified databases thereby contributing to diffuse the knowledge to the members.

The dissemination results from the activities of excellence spreading and efforts made by the organization producing basic knowledge to open data to other organisations, especially organisations coming from the country which joined recently the European Union.

The dissemination of knowledge results also from 2 other activities:

- the distribution of ASTEC by GRS and IRSN to end-users under conditions defined in a specific software agreement;
- the publications and participations to conference.

Knowledge management is a key activity of the Management Team. It has the mission to:

- Coordinate the knowledge generation through joint projects of research activities,
- Monitor the knowledge integration in ASTEC,
- Make sure that the access rights and use rights as stipulated in the Consortium agreement are correctly implemented,
- Disseminate appropriate information on the knowledge by using electronic communication links and by organizing conferences/workshops,
- Preserve the knowledge in scientific databases with long-term maintenance capacities,
- Identify the missing knowledge (continuation of EURSAFE action in the SARP work-package).

As stated earlier in this report, efforts will be done to improve (both in terms of content and of attractiveness) the SARNET public WEB site, which is an appropriate vector for disseminating the knowledge.

Furthermore, at the strategic level the Governing Board will decide with the advice of end-user representatives upon the orientations to be taken regarding missing knowledge.

3.4 Major Milestones over full project duration

The Major Milestones of the project concern:

- the deployment of linking elements such as ASTEC and the ACT;

- the elaboration of a common research programme addressing important (for nuclear safety) pending issues commonly identified and validated by end-users;
- the elaboration of a complete documentation for teaching and training in the domain of severe accidents;
- the revision of the Consortium Agreement in order to make possible the continuation of SARNET after the end of the current contract with the European Commission.

T₀ + 1 year

MM1: Full deployment of ASTEC. The code has been successfully implemented in all the organizations needing the code to carry on their tasks. Users have been trained (at least one trained user per organization). The corresponding efforts are provided by the so-called integrating activities (WP2).

MM2: The platform to be used to store experimental data has been defined. The data base feeding has been initiated. The corresponding efforts will be provided by the so-called integrating activities (WP6).

Both milestones have been reached in due time.

T₀ + 2 years

MM3: Full deployment of an ACT. The ACT is working and may be used by the contractors to access to SARNET documentation. The so-called Integrating Activities (WP1) will provide the corresponding efforts.

The milestone has been reached in due time.

MM4: Revision 1 of EURSAFE. The research priorities of SARNET have been revised; the associated document describes the topics for which research and development are still required. The so-called Integrating Activities (WP7) will provide the corresponding efforts.

The milestone has been reached in due time, the corresponding report (D40) was issued with a delay of about 6 months.

MM5: First edition of an integrated R&D SA programme. This document describes the strategy proposed by SARNET to tackle the pending issues important for reactor safety. A programme is proposed describing the research elements, but also the work distribution making the best of available competence and means. The definition of this common programme will constitute an important step toward the integration of the different national R&D strategies in the domain of severe accidents. The so-called Joint Research Activities (WP9-15) will provide the corresponding efforts.

The milestone is now planned in May- June 2007.

T₀ + 3 years

MM6: Delivery of a fully assessed version of ASTEC, including developments requested by SARNET users for VVER type reactors. The so-called Integrating Activities (WP2-4) will provide the corresponding efforts.

The milestone has been reached in due time (version V1.3 in December 2006).

MM7: Release of a SA book. The so-called Spreading of Excellence (WP18) will provide the corresponding efforts.

The milestone is now planned in Mid 2008.

MM8: Completion of SA course. The so-called Spreading of Excellence (WP17) will provide the corresponding efforts.

A first course was given in January 2006, a second one in March 2007. Other courses are planned later on.

MM9: First draft of the “post contract Consortium Agreement”. This point is particularly important since the so-called “post contract Consortium Agreement” will define the conditions in terms of organization and of funding making possible the continuation of SARNET beyond the current contract with the European Commission. An ad-hoc working group steered by the Governing Board will carry out this activity.

The milestone has been reached in due time.

T₀ + 4 years

MM10: Revision 2 of EURSAFE conclusions
MM11: Update of the integrated R&D SA programme
MM12: Signature of the new CA

4 Quality of integration and performance indicators

By its multidisciplinary structure, SARNET JPA is providing a frame for developing growing associations of complementary expertise towards covering adequately the whole range of the Physics involved in the severe accident area. Thus it is expected that, rather than trying to cover the whole range of phenomena, most organisations will progressively rely on the most competent ones for developing tools or performing tests. Thus, SARNET should lead at mid-term to a global saving at the European level in this area of research.

It is believed that ASTEC, with the strong support of the IRSN-GRS developer team, has all the qualities required to become one of the best codes in the world in reactor severe accident analysis. This is an excellent vector for integrating the research efforts of all participants, diffusing the accumulated knowledge and sharing the experience of each user.

The participants have signed a Memorandum of Understanding, making a commitment towards a deep and durable integration, beyond the period of the current contract with the European Commission.

To assess the success of the integration, the evolution of several indicators is yearly measured.

For monitoring the success of the electronic communication system:

- The number of SARNET member accesses to the SARNET Web site per month (I1);
- The number of collaborative documents elaborated and/or stored using ACT per year (I2);

For monitoring the success in using ASTEC and PSA methodology:

- The number of ASTEC users in SARNET (I3);
- The number of organisations using ASTEC for its own applications (reactor studies or test analyses) (I4);
- The number of industrial applications per year using ASTEC (I5);
- The number of Level 2 PSAs using methodology/recommendations developed by SARNET (I6).

For monitoring the success of developing collaboration in research activities:

- The number of access rights granted by contractors for applications in the frame of SARNET, or new partnerships with ISTC, VVER research programmes and advanced reactor research programmes related to Severe Accidents (I7);
- The fraction (in part of budgets) of research projects carried out in Europe that have been set-up under the aegis of SARNET per year (I8);
- The maximum number of associated organisations in a joint project (I9);
- The number of issues closed (I10);

For monitoring the scientific quality in collaborative research:

- The number of joint publications per year (I11);

For monitoring the success of the Education and Training activities and of the mobility plan:

- The number of attendees to SARNET courses or training sessions (I12);
- The number of researcher detachments (I13).

For monitoring the success of the dissemination of public knowledge:

- The number of presentation of SARNET activities in conferences (I14);
- The number of hours devoted to updating the SARNET web site for diffusing information outside SARNET (I15);
- The number of accesses to the Website from outside the Network (I16).

A yearly report on these indicators is released. Furthermore, after two years of SARNET, it appeared that some of the progress indicators are poorly adapted, so further reflexion will lead to modify some of them (Cf. SARNET Deliverable D81, then D106).

5 Detailed Joint Programme of Activities N°4 (JPA4) – month 37 to month 54

5.1 Introduction – general description, milestones, measurable objectives

The JPA4 period, from month 37 to month 54, keeps the same structure as the previous ones. It is divided into 20 work-packages, including 8 on integrating activities, 8 on jointly executed research activities, 3 on spreading excellence and 1 on management.

They are all follow up of actions initiated during the first periods, and will be conducted in parallel. The main measurable objectives of the JPA4 are:

- The organisation of 1 major event:
 - o ERMSAR 2007, European Review Meeting on Severe Accident Research and management, this event will be organised in June 2007.
- The **tentative** organisation of three courses, **without any real commitment** (organizing three courses is probably not realistic)
 - o Completion of a first version SA analysis Course at month 42,
 - o Completion of a Course on VVERs and CANDUs at month 48,
 - o Completion of a first version of PSA or SAM Course at month 54.
- The release of 2 major documents related to ASTEC:
 - o Final synthesis of ASTEC V1 validation (month 54),
 - o Final synthesis of ASTEC V1 evaluation for plant applications (month 54).
- The release of the final version of the revision of SARNET Consortium Agreement to be applied beyond the end of the current contract (hopefully extended) with the EC.
- The definition of the JPA N°5 (month 49-end of Contract as negotiated with the European Commission), with further efforts towards integration of research programmes.
- The finalized version of the first edition of the SARNET defined R&D priorities with the associated foreseen integrated R&D SA programme at month 38 (SARNET Deliverable D67). This document will describe the conclusions of the SARP group in term of research priorities and the strategy proposed by SARNET to tackle the pending issues important for reactor safety. Then this document will be commented by the SARNET AC, the experts from the EC and as many end-users as possible and a revised version (SARNET Deliverable D96) will be issued in October 2007.
- The updated version of the mobility plan (month 48).
- The final version of the SA book (month 54).

Regarding the three technical topics (Corium, Containment and Source Term), the work performed during the first three years of SARNET is now at a stable level and the activities will be pursued in the same flow as for JPA3. We can note that these activities really create strong links between partners and largely contribute to the integration through common analyses and interpretations. It is really a cement of the SARNET activities.

Finally we can also note that direct links have been constituted between SARNET and other international organisations as OECD, ISTC, etc...

5.2 Work package list/overview

WARNING: The lead contractors identified in the following tables may change during the execution of the JPA.

SARNET Work package list (54 months)

In bold N° of deliverables to be produced during the 4th JPA (JPA4: April 2007 – September 2008)

Work-package No	Work package title	Lead contractor No	Start month	End month	Deliverable N°
<i>Integrating activities</i>					
WP1	Development of an Advanced Communication Tool (ACT)	23	1	54	1, 3, 43
WP2	ASTEC Users Support and Training, Integration and Adaptation (USTIA)	1	1	54	6, 7, 34, 35, 46, 47, 48, 80, 105, 113
WP3	ASTEC PHYSical Model Assessment (PHYMA)	1	1	54	6, 8, 30, 46, 76, 80, 105, 114
WP4	ASTEC Reactor Application and Benchmarking (RAB)	1 + 23	1	54	6, 9, 31, 46, 77, 80, 105, 115
WP5	Level 2 PSA methodology and advanced tools (PSA2)	1	1	54	36, 37, 38, 70, 71, 72, 73, 75, 97, 99, 100, 101, 102, 116, 117, 118, 119, 120, 121
WP6	Implementation of Experimental Database (IED)	28	1	54	2, 39, 79
WP7	Definition of Severe Accident Research Priorities (SARP)	23	6	43	40, 67, 96
WP8	Integration Assessment (IA)	1	9	54	10, 49, 81, 106
<i>Joint research activities</i>					
WP9	EARLY phase core degradation (EARLY)	7	1	54	11,12,13,14, 15,49,50,51, 52,53,54,82, 83, 107
WP10	Late-phase Core Degradation and Vessel behaviour (LATVES)	7	1	54	11,12,13,14, 15,49,50,51, 52,53,54,82, 84, 107

Work-package No	Work package title	Lead contractor No	Start month	End month	Deliverable N°
WP11	EX-Vessel Corium REcovery (EXCORE)	7	1	54	11,12,13,14,15,49,50,51,52,53,54,82,85, 107
WP12	Hydrogen Behaviour in Containment (HBC)	21	1	54	16,17,18,19,20,49,55,56,57,58,59,86,87, 108
WP13	Fast Interactions in Containment (FIC)	21	1	54	16,17,18,19,20,49,55,56,57,58,59,86,88, 108
WP14	Fission Product Release and Transport (FPRT)	36	1	54	21,22,23,24,25,49,60,61,62,63,64,89,90, 109
WP15	AEROSol Behaviour impact on source term (AEROB)	36	1	54	21,22,23,24,25,49,60,61,62,63,64,89,91, 109
WP16	CONTainment CHEMistry Impact on source term (CONTCHEM)	36	1	54	21,22,23,24,25,49,60,61,62,63,64,89,92, 109
<i>Spreading of excellence activities</i>					
WP17	Education and Training (ET)	32	1	54	32,33,41,78, 104, 122
WP18	BOOK on severe accident phenomenology (BOOK)	32	1	54	42,69, 103, 123
WP19	MOBility programme (MOB)	32	1	54	4, 5,45;68
<i>Management activities</i>					
WP20	MANAGement (MANAG)	1	1	54	26,27,28,29,44,65,66,74,93,94,95, 98, 110, 111, 112, 125
20	TOTAL				125

WP1 is essential for making easier the communication between the Coordinator and all the participants and reducing the number of meetings. The main development effort has been produced during the first year, beyond this year a lower but constant effort is produced to improve the tool, which is already an efficient tool, widely used by the SARNET participants.

ASTEC WP2 to WP4 are continuous actions. WP2 is a key one for a strong use of the code and for extending its capacity to most of water-cooled NPPs in Europe. WP3 is a key action in the integration

process of the knowledge generated by the research activities in WP9 to WP16. WP4 allows to evaluate and improve the capability of ASTEC to simulate reactor transients in the different NPP types, including safety systems and main Severe Accident Management (SAM) procedures.

WP5 allows, as far as possible, to progress towards a better harmonization of PSA2 methodology within Europe.

WP6 will make easier the access to the data for model qualification (WP3) and also contribute to knowledge preservation and diffusion.

WP 7 will use this as an input together with the states of the art and the recommendations issued by research activities (WP9 to WP16), PSA2 (WP5) and end-users to make appropriate recommendations to the Governing Board on the orientations to be given to the research in SARNET.

WP8 allows a good monitoring of the progress as regards integration.

WP9 to WP16 are focused on the issues identified by EURSAFE (plus potential updates) as being remaining outstanding safety issues. They will contribute to resolve them while promoting the development of collaborations between participants.

WP17 to WP19 have the mission to contribute to the spreading of excellence. They will have links with WP2 on ASTEC, WP5 on PSA and more generally all research activity work-packages.

WP20 will have a strong interface with all the work-packages.

5.3 Graphical presentation of work packages

The main links between the work-packages are illustrated below:

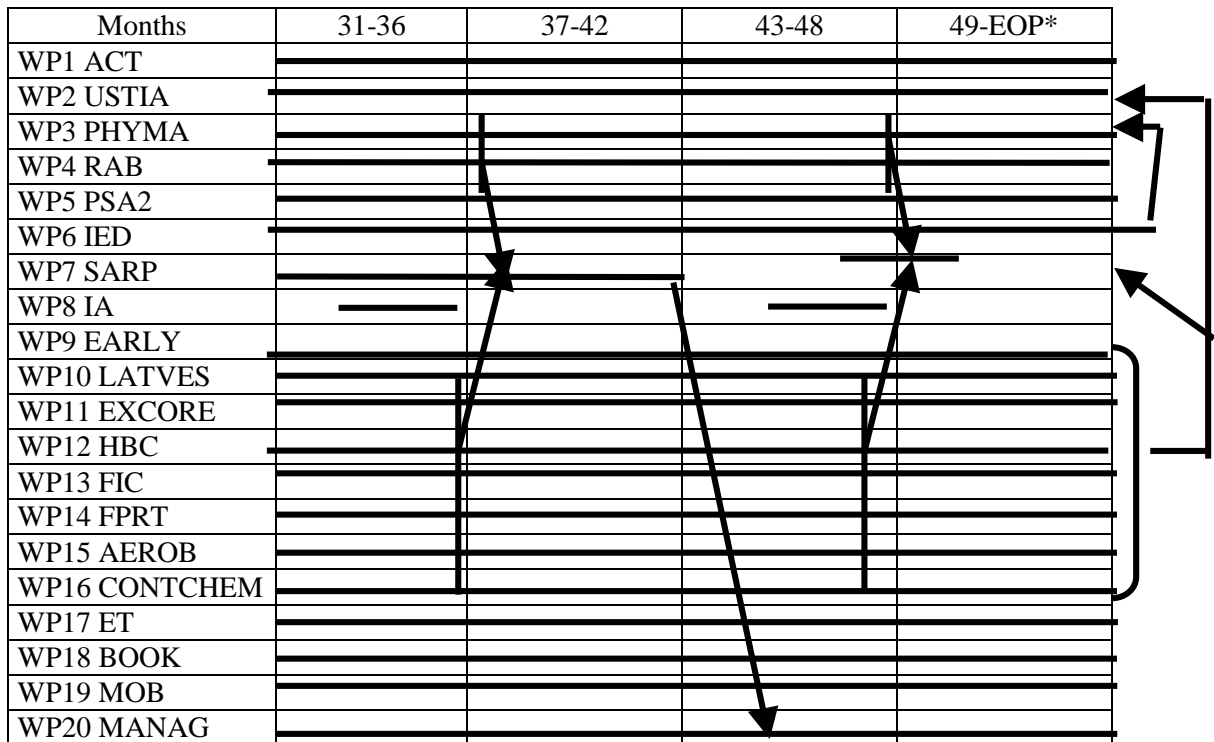

* EOP = End of Project

5.4 Detailed description, planning and time table

The following tables present the different work packages.

The person.month figures correspond to announced commitments of the partners. Nevertheless, they have to be considered as orders of magnitude and they will be adapted from month 48 both as a function of the real involvement of the partners and of the costs that the partners will be able to justify on their cost statements. This remark is particularly relevant to WP6, 7, 17, 18 and 19 in which some uncertainties remain.

Development of an Advanced Communication Tool (ACT)

Work package number	1	Start date or starting event:	37
Activity Type	Integrating activities		
Participant id	23		
Person-months per participant	3		

Objectives

Maintenance of the ACT, user support, evaluation of users' feedback and structuring of knowledge and information content of the ACT. Maintenance and extension of the Web Site

Description of work

Note that task 1.1 to 1.4 have been achieved during SARNET first year.

ACT and the SARNET public web site have been developed during the first year of SARNET project. The follow-up described below concerns the ongoing maintenance of ACT, the update of information available on the public WEB-Site and the creation of knowledge maps for structuring and navigating information in the ACT

The work will be split into five tasks:

Task 1.5: Maintenance of the ACT

- Maintenance of the Server (Software upgrades)
- Maintenance of the ACT (user administration, administration of user rights, backup and restore facilities)
- Reporting on portal usage including performance indicators

Task 1.6: Support of Users

- Support in handling document management and collaboration features of the ACT
- Help in setting up new shared sites and workspaces

Task 1.7: Evaluation of user feedback and extension of functionality (if required)

- Evaluation of a survey conducted to assess the user satisfaction
- Evaluation of proposals for improvement of existing functionality
- Development of new functionality (if required)

Task 1.8: Structuring and mapping the information content of the ACT

- Extending and completing the draft of knowledge maps for the ASTEC and CORIUM topic
- Creating knowledge maps for the other SARNET topics
- Installing the knowledge maps in the ACT for improving navigation and information retrieval

Task 1.9: Extending the public Web Site

Addition of information and of important, publicly accessible documents as the project evolves

Deliverables

Contribution to SARNET progress Report at month 48: D111

Milestones and expected result

Continuous updating and improvement of ACT and of public Web site.

Improvements in the ACT according to user feedback

Knowledge and information maps of SARNET topics by month 48

ASTEC Users Support and Training, Integration and Adaptation (USTIA)

Work package number	2		Start date or starting event:								37			
Activity Type	Integrating activities													
Participant id	1	4	6	7	10	13	14	15	16	18	21	23	24	
Person-months per participant	13.5	1	1	12	1	1	1	1	1	1	1	9	15	
Participant id	25	26	27	30	31	32	33	35	36	37	42	43	46	
Person-months per participant	8	1	1	1	1	12	5	1	2	1	1	1	1	
Participant id	47	49	51	53	54									
Person-months per participant	1	1	1	1	1									

Objectives

Distribute the code versions and their documentation to code users.

Provide a support for code users.

Organize information exchange between ASTEC users.

Capitalize the knowledge by integration of models proposed in the 3 SARNET Topics Corium, Containment and Source Term.

Improve and adapt the code to meet the users requirements, particularly the extension to most types of reactors.

Description of work

Task 2.1: Code release and support to code users.

The IRSN-GRS team will:

- analyse the requests of ASTEC users and propose solutions (error corrections, minor development)
- update the code and make these updates available
- deliver code versions and documentation to all SARNET partners, in the JPA4 period: ASTEC V1.3 updates (rev1 in May 07 and possibly next updates according to maintenance feedback).

Task 2.2. Users Club

All the organizations participating to the ASTEC Topic will participate to the ASTEC Users Club meetings that will be periodically organized in order to exchange information on the code use, examine the code status regarding its development and assessment, examine users requests and discuss their priority, and prepare recommendations to be addressed to the Governing Board. The 3rd User Club meeting is planned in March 2008 (it will also serve as 4th ASTEC Topic progress meeting).

The ASTEC Web site on ACT (link with WP1) will be continuously developed and maintained to make easier exchange of information and documents between maintenance team and users.

Task 2.3. Training and learning

All the organisations involved in the ASTEC Topic will participate to this activity (host, teach or learn). Training sessions will be periodically organized. E-learning will be organized (on ASTEC Web site) and maintained.

During the JPA4 period, one training session on code use for beginners could be organized (if judged necessary by partners) in early 2008. The organisation of specialized training sessions for experienced users must be discussed with all partners.

Task 2.4: Code developments (in continuity of JPA3 work)

- Detailed specifications for the extension to BWR, CANDU and RBMK, and, if possible, start of model adaptations,
- Specifications of missing models of the different systems for SAM as requested by ASTEC users, and associated developments, for instance on vessel external cooling,
- Permanent synthesis of requests on ASTEC development, issued from outcomes of the Users' Club meetings and of other WP of SARNET (corium, containment, source term, PSA2).
- Model developments by partners to improve the existing modelling (including those issued from outcomes of other SARNET Topics).

Deliverables

Final synthesis of ASTEC adaptation to different reactor types and safety systems and modelling developments by partners (D113) at 54 months

4th annual general Progress Report on topic ASTEC (D105) at 48 months

Milestones and expected result

Delivery of ASTEC V1.3rev1 in May 2007

ASTEC V2 development and validation plan end of 2007

3rd Users club meeting in March 2008

Project Planning Time Table

WP2 Tasks	USTIA	Lead. 1	Months 37-42	Months 43-48	Months 48-54
MEETINGS				M	
		Part. Id.			
2.1	V1.3rev1 release of code and user documentation	<i>1, 23</i>	→WP3 →WP4	D105	
2.2	Users clubs	<i>1, 23 + Users</i>		---M	D113
	ASTEC Web site update	<i>1</i>	-----	----- D105	----- →WPI
2.3	Training session	<i>1, 23 + Users</i>		---M ?	
2.4	Adaptation to other reactors and systems	<i>1, 23, 24, 25, 32, 33, 36, 53</i>	-----	----- D105	----- D113
	Model developments	<i>7</i>	-----	----- D105	----- D113
	Account of requirements for V2 development	<i>1, 23</i>	-----	----- D105	----- D113

—————> Indicates main dependences between tasks

Users = 1, 4, 6, 7, 10, 13, 14, 15, 16, 18, 21, 23, 24, 25, 26, 27, 30, 31, 32, 33, 35, 36, 37, 42, 43, 46, 47, 49, 51, 53, 54

ASTEC Physical Model Assessment (PHYMA)

Work package number	3		Start date or starting event:										37
Activity Type	Integrating activities												
Participant id	1	4	6	7	10	16	21	23	24	25	26	27	30
Person-months per participant	9	1.5	3.5	4	8	9	8	4.5	6	2	5	7	15
Participant id	31	33	43	47	53	54							
Person-months per participant	5	2	6	3	1.5	1							

Objectives

Assess the physical models of the ASTEC code through comparison to experimental results.

Description of work

This activity consists of comparison of ASTEC with experimental data; exceptionally experimental data can be replaced by results provided by detailed reference codes, whose models are mainly more detailed and assessed than the ASTEC ones (example: CFD codes compared to CPA multi-compartment containment part of ASTEC).

The work organization during the JPA4 period is:

Task 3.1: Assessment work for the version V1.3 and its updates based on the large validation matrix defined in JPA2. A regular distribution of work will be searched between all physical phenomena and between NPP specificities.

Task 3.2: Update of the general validation matrix and of the reference corresponding input decks.

This activity will be shared between 18 organisations, according to their competence:

- In-vessel phenomena (thermal-hydraulic and degradation phenomena): AECL, BNRA, BUTE, CEA, ENEA, FZK, IKE, INR, INRNE, IVS, JRC-Petten, LEI, UJV,
- Ex-vessel corium (MCCI, DCH): ARCS, GRS, IRSN, TUS,
- Containment thermal-hydraulic behaviour: ENEA, GRS, IRSN, JRC Petten, JSI,
- Source term: CIEMAT, ENEA, GRS, IRSN, JRC Petten, JSI, TUS,
- Integral tests (Phébus.FP): IRSN, JRC Petten

Deliverables

4th yearly general Progress Report on topic ASTEC (D105) at 48 months

Final synthesis of ASTEC V1 validation (D114) at 54 months

Milestones and expected result

Final synthesis of ASTEC V1 assessment in October 2008

Project Planning Time Table

WP3 Tasks	PHYMA	Lead. 1	Months 37-42	Months 43-48	Months 48-54
MEETINGS				M	
		Part. Id.			
3.1	In-vessel corium	<i>CIV</i>	-----	-----D105	-----
	Ex-vessel corium	<i>CEV</i>	-----	-----D105	-----
	Containment	<i>CCO</i>	-----	-----D105	-----
	FP	<i>CFP</i>	-----	-----D105	-----
	Integral tests	<i>CIT</i>	-----	-----D105	-----
3.2	Validation matrix update	<i>All</i>	-----	-----D105	-----

----->Indicates dependence between tasks

CIV= 6, 7, 16, 21, 24, 25, 26, 27, 30, 33, 47, 53, 54

CEV= 1, 4, 23, 43

CCO= 1, 16, 23, 30, 31

CFP= 10, 16, 23, 30, 31, 54

CIT= 1, 30

ASTEC Reactor Application and Benchmarking (RAB)

Work package number	4		Start date or starting event:								37			
Activity Type	Integrating activities													
Participant id	1	6	14	15	16	18	23	24	25	26	27	32	33	
Person-months per participant	9	11.5	4	2.7	8	2.7	8	4	8	12	10	6	11	
Participant id	35	42	43	46	47	49	51	53	54					
Person-months per participant	2.7	3	7	11	1.5	17	17	1	4					

Objectives

Evaluate and improve the capability of ASTEC to simulate reactor transients.

Description of work

This activity will provide inputs for the WP2 and WP7. The reactor transients will concern 5 types of reactors: PWR, BWR, VVER, CANDU and RBMK. ASTEC will be compared on reactor transients with the integral codes MELCOR and MAAP and with some specialized codes such as: ICARE/CATHARE, ATHLET-CD, RELAP-SCDAP, COCOSYS, TONUS ...

The work organization during the JPA4 18-months period is:

Task 4.1: Reactor calculation and benchmarking activity with the version V1.3 and its updates, based on the large reactor sequence matrix defined in JPA2.

Task 4.2: Update of the ASTEC reference input decks for PWR, VVER, CANDU and RBMK reactor applications.

This activity will be shared between 22 partners. The application scope will be extended to other accident scenarios or to other SAM than in JPA3. Some benchmarks could focus on specific parts of the sequences. Sensitivity calculations will be performed.

The benchmarking work will be distributed as follows for the different reactor types:

- PWR: EdF, EA, ENEA, AREVA-NP SAS, GRS, IRSN, IKE, NRG, TRACTEBEL
- VVER-440: BUTE, IVS, UJD, VEIKI, VUJE
- VVER-1000: BNRA, INRNE, KTH, TUS, UJV
- BWR: KTH,
- CANDU: INR, AECL
- RBMK: LEI

Deliverables

4th yearly general Progress Report on topic ASTEC (D105) at 48 months

Final synthesis of ASTEC V1 benchmarking activity (D115) at 54 months

Milestones and expected result

Final synthesis of ASTEC V1 assessment in October 2008

Project Planning Time Table

WP4 Tasks	RAB	Lead. 1	Months 37-42	Months 43-48	Months 48-54
MEETINGS				M	
		Part. Id.			
4.1	PWR	<i>CPR</i>	-----	----- D105	-----
	VVER-1000	<i>CVIR</i>	-----	----- D105	-----
	VVER-440	<i>CV4R</i>	-----	----- D105	-----
	RBMK	33	-----	----- D105	-----
	CANDU	25, 53	-----	----- D105	-----
	BWR	32	-----	----- D105	-----
4.2	Update of input deck data base	<i>1, 23, 25, 26, 32, 33, 42, 51</i>	-----	----- D105	-----

----->Indicates dependence between tasks

CPR = 1, 14, 15, 16, 18, 23, 24, 35, 42

CVIR = 26, 32, 43, 47, 54

CV4R = 6, 27, 46, 49, 51

Level 2 PSA Methodology and Advanced Tools (PSA2)

Work package number	5				Start date or starting event:					37 (April 2007)				
Activity Type	Integrating activities													
Participant id	1	5	7	11	15	19	23	25	30	33	34	36	39	
Person-months per participant	7	2	3	4	2	3	3	3	3	3	3	3	3	
Participant id	43	44	47	48	49									
Person-months per participant	2	4	4	13	5									

Objectives

Compare, improve and harmonize the methodologies used for developing Level 2 PSA within European countries and share effort to develop advanced tools, as far as they are required.

Identify most critical knowledge difficulties in continuation with EURSAFE for R&D prioritisation.

Adapt methodologies for application to the reactor types used in the NAS countries.

Description of work

WP 5.1: Comparison of Level 2 PSA approaches, identification of improvement needs and recommendations of methods:

- An eventual revision of SARNET PSA2 – D71 deliverable (proposal of possible harmonized methods to assess hydrogen combustion and immediate consequences of vessel breach) according to other SARNET WP comments,
- Finalization of the proposal of harmonized methods to take into account in a level 2 PSA corium and concrete interaction and to assess iodine releases and (SARNET PSA2 – D72 deliverable),
- Review of main existing guidelines for level 2 PSA development,
- On the base of partners' own definitions comparison for "large early releases frequency" and for "reactor safe state", and as far as possible, harmonized definitions will be provided (deliverable SARNET PSA2 - D99),
- Principles of harmonization of the methods to take into account in a level 2 PSA the different physical phenomena (deliverable SARNET PSA2 - D100) ,
- On the base of partners' methods detailed description and comparison, common views on Plant damage states (PDS) and level 1/level 2 interface variables definition will be searched, advantages and disadvantages of integrated level 1/level 2 PSA, requirements for probabilistic software for such PSA will be identified(SARNET PSA2 deliverable),
- Revision, as far as possible of SARNET PSA2 – D75 deliverable (use of guidelines for level 2 PSA development and on themes for which harmonization seems possible and relevant) to take into account non SARNET partners view,
- Requirements for ASTEC use in a level 2 PSA (SARNET PSA2 deliverable),
- Investigations on the possibility of ASTEC coupling with probabilistic codes.

WP 5.2: Comparison of methodologies for assessment of uncertainties and identification of improvement and harmonization needs:

- Finalization of the proposal of harmonized methods to take into account in a level 2 PSA uncertainties related to corium and concrete interaction and to iodine releases (SARNET PSA2 – D72 deliverable).
- Achievement of the SARNET PSA2-D101 deliverable (review of tools for uncertainty and sensitivity analysis methods in support to level 2 PSA development with description of the different tools functionalities),
- Description of methods to take into account cliff edge effects,

WP 5.3: Improvement of event tree methodology using dynamic reliability techniques:

- o Revision of the specification of the benchmark exercise on hydrogen combustion issue for comparison of classical and dynamic reliability methods, including separation of epistemic and stochastic uncertainties (to be quantified separately),

- Introduction of delays in human actions achievements (core reflooding, spray system operating),
- Better modelling of steam condensation.
- Achievement of the step 3 of the benchmark and final conclusion of the benchmark (SARNET PSA2 deliverable),
- In parallel, continuation of the development of the platform including the development of the SDTPD method

Deliverables

Report on recommendations on best estimated methods to take into account, MCCI, iodine releases in a level 2 PSA and corresponding uncertainties (D 72) at 38 months

Definitions of "large early releases " and of "reactor safe states" in the frame of a level 2 PSA (D99) at 42 months

Report on recommendations of methods to take into account physical phenomena in a level 2 PSA (D100) at 42 months

Review of software that could be used for uncertainty and sensitivity methods in support of PSA level 2 (D101) at 42 months

Status report on SDTPD method development (D102) at 42 months

Harmonized methods for level 1 and level 2 PSA interface 48 months (D116)

Expert judgment use in level 2 PSA at 48 months (D117)

Final report on harmonization of methods at 54 months (D118)

ASTEC requirements for level 2 PSA use at 54 months (D119)

Benchmark exercise on comparison between dynamic reliability methods and classical ones conclusions at 54 months (D120)

Conclusions on SDTPD method development and its possible use for level 2 PSA application at 54 months (D121)

Milestones and expected results

2 general meetings per year expected: coordination of the activities

Better harmonization of level 2 PSA methods (see deliverables dates)

Definition of requirements for ASTEC and investigation of ASTEC coupling with probabilistic code (54 months)

Development of dynamic reliability methods and conclusions about their possible use for level 2 PSA application (54 months)

Project Planning Time Table

WP5 Tasks	PSA2	Lead. 1	Months -37 - 42	Months 42-48	Months 48-54
MEETINGS (see Tasks)					
		Part. Id.			
5.1	Comparison	<i>List 5.1</i>	D75 D72 →WP2	D99 D100	D116 D117 D118 D119
5.2	Uncertainty	<i>List 5.2</i>	D72 →WP2	D100 D101	D116 D117
5.3	Dynamic reliability	<i>List 5.3</i>	D102		D120 D121

List 5.1: 1, 5, 11, 15, 19, 23, 25, 33, 34, 36, 39, 43, 47, 49

List 5.2: 1, 7, 11, 15, 19, 23, 30, 33, 34, 36, 39, 43, 47, 49

List 5.3: 1, 7, 11, 15, 19, 23, 25, 33, 36, 44, 47, 48, 49

Implementation of Experimental Database (IED)

Work package number	6		Start date or starting event:								37		
Activity Type	Integrating activities												
Participant id	28	1	3	7	8	10	17	21	23	32	50		
Person-months per participant	3	3	3	3	6	3	3	3	3	3	3		

Objectives

Provide SARNET with, develop and maintain an instrument that ensures preservation, easy access for codes, exchange and processing of Severe Accident experimental data

Description of work

Task 6.2: Introducing in the network of organisations that were not part of the EURSAFE activity on the database, and support to the others:

- Creation of local STRESA nodes for the newcomers
- Organisation of one-week training for these organisations

Providing support for establishing the links with communication tool developed in WP1.

Task 6.3: Completing the existing EURSAFE database network developed from STRESA structure with the other available severe accident data of the participating organisations.

- Data from PLINIUS platform: VULCANO, COLIMA (CEA)
- Data from KJET, PREMIX, ECO, QUEOS, DISCO (FZK)
- Data from FOREVER, KMFCL, POMECO (KTH)
- Data from Phébus.FP (FPT0, FPT1) and VERCORS (IRSN)
- Data from CODEX: core degradation bundle tests (AEKI)
- Data from VICTORIA and HORIZON: Helium and aerosol experiments (FORTUM)

During the period 37-54 months the Implementation of Experimental Databases (IED) will be concentrated on:

- a) maintenance of existing overall DATANET structure
The DATANET structure needs to be periodically checked in order to identify missing links or problems that can prevent the free use of the experimental data. Backup facilities are also implemented to avoid data losses.
- b) Organization of 2 training courses on the use of STRESA database
Two training courses will be organized, one in June 2007 and another in June 2008 on the use of STRESA database. Over the years it was recognized that the optimum period is 3-4 intensive days in which the trainee is instructed to convert the data, setup and maintain the STRESA database in his organization.
- c) STORM data conversion and storage: collection of STORM experimental data and conversion in STRESA format; organization of the STRESA database for STORM facility
The STORM experiment produced a large amount of experimental data which are still useful for analysis purposes.. However the data have been stored in an old type medium and need to be restored. Once they are restored they can be converted in the STRESA format and archived in the STRESA-JRC database. This work should be completed by CESI RICERCA with some help from JRC-ISPRA.

Deliverables

Data base catalogue, revision 1 (D79) at 48 months

Milestones and expected result

STORM data conversion and storage completed at month 48.

Project Planning Time Table

WP6 Tasks	IED	Lead. 28	Months 37-42	Months 43-48	Months 49-54
MEETINGS			M		
		Part. Id.			
6.2	Deployment by partners	<i>List 6.2</i>	-		
	Deployment continuation and user support	28			
6.3	Data Base Completion	<i>List 6.3</i>		-----D79	

List 6.2: to be defined

List 6.3: 28, 1, 3, 7, 8, 10,17, 21, 23, 32, 50

Definition of Severe Accident Research Priorities (SARP)

Work package number	7			Start date or starting event:						37			
Activity Type	Integrating activities												
Participant id	23	1	7	15	21	32	43	50					
Person-months per participant	4.5	3	3	3	3	3	3	2					

Objectives

Prioritise the research to be performed in the field of severe accident phenomena and management, notably using the results of EURSAFE, and ASTEC and Level 2 PSA work packages

Description of work

- Agree on methodology
- Review issues resulting from EURSAFE not appropriately covered by SARNET
- Analyse R&D progresses and results from Level 2 PSA studies
- Review issues ranking
- Review potential experimental and theoretical programmes to address these issues
- Make recommendations for R&D programme revision

Deliverables

Updated version of SARNET R&D strategic plan, with if necessary revision of the R&D priority index (D67 then D96) at 38 then 43 months.

Milestones and expected result

Updated SARNET Integrated R&D elaborated in the frame of Joint Research Activities WPs at 43 months: D96

Project Planning Time Table

WP7 Tasks	SARP	Lead. 23	Months 37-42	Months 43-48	Months 49-54
MEETINGS			M		
		Part. Id.			
7.2	Revision of EURSAFE conclusions/ proposals	<i>List 7</i>	D67-----	D96	

List 7: 23, 1, 7, 15, 21, 32, 43, 50

The JRA (Joint Research Activities) provide inputs during the revision process.

The revision leads to recommendations to be integrated in the update of the JRA.

Integration Assessment (IA)

Work package number	8			Start date or starting event:					37				
Activity Type	Integrating activities												
Participant id	1	7	21	23	30	32	36						
	0.5	0.5	0.5	0.5	0.5	0.5	0.5						

Objectives:

To monitor the progress of the network and propose corrective actions in order to reach the SARNET objectives.

Description of work

Task yearly carried out, 3 months before the release of the annual report.

The Coordinator, concerned Scientific Coordinators and some WP leaders carry out the work.

The work consists in:

- Collecting the information necessary to measure the evolution of the 16 indicators defined in chapter 7;
- Analysing the results, and propose if necessary JPA corrective actions;
- Proposing the revision of the list in order to make easier the assessment.

Among the 16 indicators, the following ones are considered as the most significant:

- I1: number of member accesses to the Web site
- I2: number of collaborative documents elaborated and/or stored using ACT
- I3: number of ASTEC users in SARNET
- I4: The number of organisations using ASTEC for its own applications
- I7: the number of access rights granted to contractors for application in SARNET
- I11: the number of joint publications/communications
- I12: the number of attendees to SARNET course or topical trainings
- I13: the number of researcher detachments
- I14: the number of presentations of SARNET
- I15: the number of hours devoted to updating SARNET Web site
- I16: the number of accesses to the public Website

Deliverables

Annual indicator assessment report D106 at 48 months

Milestones and expected results

Continuous improvement of the process leading to fulfil SARNET objectives.

Early-phase core degradation (EARLY)

Work package number	9		Start date or starting event:					37		
Activity Type	Other specific activities									
Participant id	1	15	16	21	23	25	26	36	37	47
Person-months per participant (18 months)	5.3	2.7	4.5	4.65	1.35	2.4	6	4.5	4.5	2.25

Objectives

These issues result from:

- Selection of the research issue N°1.1 in 5th FWP EURSAFE project with following selection rationale: rapid generation of hydrogen which may not be accommodated by re-combiners and risk of early containment failure; improve knowledge about the magnitude of hydrogen generation.
- Conclusions of the COLOSS 5th FWP project and preparation of Phébus FPT3 test which showed needs of improvements of understanding and modelling of B₄C impact on core degradation. Same conclusions for irradiated fuel dissolution.
- For oxidation and hydrogen production in a damaged core, oxidation by air has been stressed during EURSAFE PIRT exercise. Ranked at level 2 for core degradation there is nevertheless a strong impact of oxidising environment on the fuel and on the fission products release especially for Ruthenium. Initially addressed in WP14, the Zircaloy oxidation by air or by steam-air mixtures issue will be identified separately within WP-9 and constitute the initial conditions fuels rods behaviour and fission products release. The phenomenon of air oxidation may also occur during abnormal fuel management operations.

A more complete understanding is needed on the following physical processes: hydrogen generation during core reflooding conditions (esp. oxidation of metal-rich mixtures), B₄C and fuel burn-up impact on core degradation for various atmosphere conditions (steam, air and steam/air mixtures), and more generally the remaining questions in the core degradation early-phase (in particular, oxidation of clad with advanced alloys and hydrogen generation during melt relocation into water present in the vessel lower plenum).

The main work-package objective will be the progressive integration of the R&D capacities on these issues, in order to better coordinate the research activities and optimise the available competences and resources.

This will be done particularly through:

- Joint investigation of the physical processes in order to reach a common understanding through syntheses on experimental programs and on their interpretation.
- Development of adequate models for the above physical processes to be implemented into ASTEC.

This will lead to the definition and proposal of a joint R&D programme (models, experiments) to solve this issue, either by re-orientation of existing programmes or by launching new ones.

Description of work

Task 9.1. Hydrogen generation during core reflooding

Continuation of review and selection of available experiments/models for interpretation and modelling activities. Joint recommendations on the test specifications (design and test matrix...).

The current JPA is mainly concentrated on the QUENCH test series and supporting Separate Effect Tests:

- Preparation and conduct of bundle test QUENCH-13 with SIC Control Rods.
- Separate effect tests at FZK for the comparison of steam oxidation of different cladding materials (Zry-4, Duplex, M5, E110, Zirlo) at high temperatures.
- Post test calculation of the QUENCH-11 and QUENCH-12 tests with MELCOR, SCDAP, ICARE/CATHARE, ATHLET-CD.

- Contribution of PSI to the QUENCH test pre-calculations and definition.
- Calculation of ongoing QUENCH tests with MELCOR and MAAP (for the SIC test).- Joint authorship (FZK, PSI) of the report published on QUENCH-11 and 12 pre-calculations.

The QUENCH Workshop (November 2007) will serve as a mid term technical meeting of the WP9.1 partners.

Final analyses of the QUENCH-11 Benchmark. Joint paper at ERMSAR and Final Workshop in May/June 2007.

Other activities will concern:

- Interpretation of the CORA-13 test with ICARE/CATHARE and of CORA-28 with ATHLET-CD.
- Interpretation of PARAMETER tests and modellisation of U₂O₃ oxidation and top flooding.

Task 9.2. Early core degradation and B₄C effects

Analysis of Phébus FPT2, FPT3 and QUENCH/ B₄C tests results with SCDAP, ICARE/CATHARE, ATHLET-CD and MAAP4.

Preparation, performance and analysis of remaining BECARRE part II experiments on B₄C/stainless steel mixtures, and then of BECARRE part III experiments on B₄C short rods on MAESTRO platform .

Interpretation and modelling of the oxidation tests (BECARRE part II) on B₄C/stainless steel mixtures.

Improvement of B₄C/stainless steel melt oxidation models.

The Autumn Phébus BIC meeting will serve as a mid-term technical meeting of WP9.2 partners

Task 9.3. Zircaloy oxidation by air and steam-air mixture

Common analysis of the separate effect tests data produced during previous periods. Production of a common ERMSAR paper.

Separate effect tests at FZK for the comparison of air oxidation of different cladding materials (Zry-4, Duplex, M5, E110, Zirlo) at high temperatures

Preparation, performance, analysis and interpretation of MOZART experiments. ENEA will contribute to define the conditions of IRSN thermogravimetric tests with N₂ rich atmospheres.

Small scale tests at INR for evaluation of the effect of Zirconium hydride and nitride layers on Zy4 oxidation.

A detailed review of Zircaloy/air oxidation experiments will be conducted with view in proposing improved models (PSI). The air ingress model of ICARE/CATHARE (IRSN) will be improved. Based on IRSN and FZK improved modelling of air oxidation, EDF will improve MAAP4 models and validate them against QUENCH-10 test. GRS will work on air oxidation model development, to take into account the effect of nitrogen. New CODEX AIT-1 and QUENCH-10 calculations.

GRS will interpret QUENCH-10 and Separate Effect Tests with ATHLET-CD. This shall lead to an improved modelling of Zr oxidation by air/steam mixture, exploring in particular the role of nitrogen.

Deliverables

Contribution to Progress report on CORIUM topic (D107) at 48 months

Milestones and expected result

Technical milestones associated to benchmark exercises are detailed on road map defined by sub-topics leaders.

Fourth period conclusion meeting, assessment of work and definition of future joint R&D at 47 months.

LATe-phase Core Degradation and VESsel behaviour (LATVES)

Work package number	10		Start date or starting event:						37	
Activity Type	Other specific activities									
Participant id	1	7	15	21	22	23	24	27	32	41
Person-months per participant (18 months)	3.5	1.65	0.9	3	4.5	1.8	2.25	4.5	3	1.0

Update: Just when issuing this report, the SARNET Coordinator learns that PSI (Partner N°36) will join the WP10, with an involvement of 1 person-month, on the interpretation of TMI-2 melt pool behaviour using available late phase models and on the preparatory work for reference plant studies. The tables will be updated with the next revision of the present document.

Objectives

The rationales for these issues result from 5th FWP EURSAFE project:

For late-phase degradation and corium behaviour in lower head, Research issue N°1,3 with following selection rationale: Improve predictability of the thermal loadings on RPV lower head (or corium catcher devices) to maintain their integrity. It is also related to the Research issue N°1.4 “External vessel cooling and RPV integrity” for in-vessel melt retention strategies.

For vessel integrity and corium release to cavity, Research issue N°1,6 with following selection rationale: Improve predictability of mode and location of RPV failure to characterise the corium release into the containment. This addresses also part of Research issue N°3.1 “Melt relocation into water and particulate formation” through the melt relocation from core region into water filled space.

A more complete understanding is needed on the following physical processes:

For coolability of a molten corium pool in the lower plenum or in an external core-catcher: in case of dry cavity, initial corium characteristics from the core region when relocating to the lower plenum, and behaviour of molten pool in the lower plenum (segregation/stratification, heat transfers to boundaries...); in case of external vessel cooling, critical heat flux and external cooling conditions in order to evaluate and design AM strategies for in-vessel melt retention.

For vessel integrity and corium release to cavity: in conditions of dry cavity, vessel mechanical failure (mode, instant, location) due to thermal and mechanical loadings, and breach opening processes and characteristics of corium release to the cavity.

The main WP objective will be the progressive integration of the R&D capacities on these issues, in order to better coordinate the research activities and optimise the available competences and resources.

This will be done particularly through:

- Joint investigation of the physical processes in order to reach a common understanding through syntheses on experimental programs and on their interpretation.
- Development of adequate models for the above physical processes to be implemented into ASTEC.

This will lead to the definition and proposal of a joint R&D programme (models, experiments) to solve this issue, either by re-orientation of existing programmes or by launching new ones.

Description of work

Task 10.1. Late phase core degradation and corium behaviour in lower head

Experimental activities:

On-going experiments at the LIVE facility (FZK) with Pre and Post test calculation support (IKE, CEA, potentially KTH). Two new tests with binary NANO₃-KNO₃ melts are planned as well as the post-test analyses of last year tests.

New DEFOR Debris bed formation test.

Information on the progress of the low heat flux external vessel cooling experimental facility at CEA (for low power reactors).

Interpretation and modelling:

Interpretation of past experiments FPT4 and MASCA with ICARE/CATHARE and/or ASTEC.

New model developments, esp. modelling of molten pool behaviour, in particular stratification

Reactor Applications

Reactor applications with ATHLET-CD, emphasizing the continuous description of late phase phenomena in core and lower head, in view of contributing for modelling in ASTEC. In particular, GRS will conduct analyses of melt relocation path into lower plenum for German LWRs. Studies with ICARE/CATHARE of the phase of corium relocation from the core region to the lower plenum on PWR and interpretation of the TMI2 accident.

Task 10.2. Vessel failure and corium release to cavity

Analytical tests on plate and tube (IRSN)

Interpretation of FOREVER experiments with simplified 2D model and with the ASTER and ADINA codes, as a confirmation of the JPA3 benchmark.

Investigation of the behaviour of a pre-existing crack in the lowerhead during delayed external flooding (fracture mechanical analysis).

Improvement of the vessel mechanical failure and opening simplified model (IRSN).

3D FE studies with CAST3M of RPV failure in reactor conditions.

CEA has proposed to extend the OLHF1 benchmark to deal with the issues of breach location and final size prediction, the principle of a benchmark has been approved but its application is still under discussion.

- Integration of experimentally found correlations for RPV wall
- Corrosion due corium-steel interaction (METCOR project)

Study on the Effect of additions on steel properties (IRSN)

Unified approach to material and creep data for US, French, Russian and German types of reactor steel

Finalization of the implementation of the simplified 1D model for creep and necking.

Thermal and mechanical analyses of IVR scenarios with segregated melt (KONVOI, VVER) will be conducted at FZD.

Statistical uncertainty and sensitivity analyses for IVR scenarios

Deliverables

Contribution Progress report on CORIUM topic (D107) at 48 months

Milestones and expected result

Technical milestones associated to benchmark exercises are detailed on road map defined by sub-topics leaders.

Fourth period conclusion meeting, assessment of work and definition of future joint R&D at 47 months

Ex-vessel Corium Recovery (EXCORE)

Work package number	11		Start date or starting event:							37	
Activity Type	Other specific activities										
Participant id	1	7	15	19	21	23	24	29	32	41	47
Person-months per participant:	3.2	6.15	0.9	4.5	3.0	1.2	7.13	4.5	4.5	3	3.75
Participant id	48	50	53								
Person-months per participant:	4.5	3.3	1.5								

Objectives

The rationales for these issues result from 5th FWP EURSAFE and EUROCORE projects:

For ex-vessel case w/o water injection (EURSAFE items N°2.1 “MCCI: molten pool configuration and concrete ablation” and N°2.3 “Ex-vessel corium catcher: corium ceramics interaction and properties”): improve predictability of axial versus radial ablation up to late phase MCCI to determine basemat failure time and loss of containment integrity; demonstrate the efficiency of specific corium catcher designs by improving the predictability of the corium interaction with corium catcher materials.

For ex-vessel case with water injection (EURSAFE items N°2.2 and 2.4): increase knowledge of cooling mechanisms by top flooding the ex-vessel corium pool to demonstrate termination of accident progression and maintenance of containment integrity; demonstrate efficiency of water bottom injection to cool corium pool and its impact on containment pressurization.

The scope of the work-package is extended also to particulate debris coolability for in-vessel situation (EURSAFE item N°1.2): termination of the accident by re-flooding of the core while maintaining RCS integrity. Increase predictability of core cooling during re-flooding.

A more complete understanding is needed on the following physical processes:

For corium behaviour during interaction with concrete or ceramic and for ex-vessel pool corium coolability: pool stratification and layers stability under gas sparging; heat transfer mechanism, power distribution and ablation homogeneity; fission product remaining in the pool; ceramic dissolution mechanisms; cooling mechanisms with water on top of the melt (bulk cooling, water ingress or melt ejection); crust anchorage phenomena in reactor pit and consequence for melt ejection mechanism; porosity formation during cooling by bottom injection of water into the melt and consequences for water management and steam production.

For core coolability: behaviour of ex-vessel particulate debris beds in water present in the cavity. thermal hydraulics of debris beds, without or with water injection, coolability of debris beds (in- and ex-vessel), coolability of the molten pool within the core, fuel rod collapse and molten pool crust failure.

The main WP objective will be the progressive integration of the R&D capacities on these issues, in order to better coordinate the research activities and optimise the available competences and resources. This will be done particularly through:

Joint investigation of the physical processes in order to reach a common understanding through syntheses on experimental programs and on their interpretation.

Development of adequate models for the above physical processes to be implemented into ASTEC.

This will lead to the definition and proposal of a joint R&D programme (models, experiments) to solve this issue, either by re-orientation of existing programmes or by launching new ones.

Description of work

Task 11.1. Core and debris coolability during reflooding

Experimental activities

Joint analyses, in view of proposing models for ASTEC, of past and current experiments:

Friction laws based on STYX (VTT), POMECO (KTH) and DEBRIS (IKE) experiments, including data on realistic debris from DEFOR (KTH).

Top and bottom quenching experiments (from Tutu or Ginsberg to DEBRIS and POMECO).

The results of the DEFOR experiments will be assessed with respect to the effects of debris bed characteristics on corium coolability.

Interpretation of DEBRIS and SILFIDE experiments with ICARE/CATHARE V2 code.
First specifications of the new IRSN 2D debris bed quenching experiment.

Codes and modelling

The WABE code (developed at IKE) will be used, validated and applied at KTH and VTT.

IRSN will stress on the modelling of thermal-hydraulics of reflooding of intact and degraded cores

IRSN will derive, during months 49-54, recommendations for further experiments and model development.

Reactor case applications

Applications to reactor cases, in order to check the relevance of differences and uncertainties in basic laws and their applicability, and to evaluate cooling options and scenarios. An utility (EDF) will contribute to the analysis of scenarios. Sensitivity studies on reactor applications with ICARE/CATHARE V2 code. WABE will be used for Olkiluoto 1 and 2 BWR plants to assess coolability of particle bed on the pedestal floor (VTT).

Task 11.2. Molten corium-concrete/ceramic interaction

Information exchange on the VULCANO, HECLA and CCI experimental programmes, and possibly on the ISTC large scale MCCI project.

Recalculation of CCI3 test with MEDICIS code.

Interpretation of first MCCI test (CCI4) of MCCI-OECD follow-on program with MEDICIS, TOLBIAC ICB,....

Improvement of heat transfer models using results from the ARTEMIS, MCCI-OECD (including follow-on program) and VULCANO programs.

Benchmark of MCCI codes on a typical reactor scale application.

Task 11.3. Ex-vessel coolability

Improvement of the top flooding models for MCCI configurations (porosity formation, melt entrainment).

Continuation of the post test calculations on the VULCANO-COMET experiment:

further model validation of models

influence of sequential opening of inlets on porosity formation

evaluation of possible optimization of COMET PCA core catcher.

Selection and qualification of a simplified spreading model for ASTEC applicable to EPR

Refinement and validation of the KTH model

Research of a consensus between EU teams

Benchmarking between simple model(s) and mechanistic codes on reactor cases.

Applications to reactor case

Task 11.4. (WP 9/10/11) Thermodynamic and Thermophysical Databases

Concerning the thermodynamic database activities for the next 18 months the main task will be the maintenance and updating of the content taking in account the new experimental information available in SARNET and other international programs. Each year, in the first trimester, an updated version of the database is distributed to the SARNET users : CEA, EDF, IRSN, AREVA, VTT. The principal use of the database is a joint analysis and interpretation of experiments in WP9, 10 and 11 or integration in codes such as TOLBIAC.

Separate effect tests are planned at ITU. CEA will compare the results of GEMINI calculations with experimental data arising from experiments performed within SARNET or within related ISTC projects.

Since these inputs rely largely on post-test material analyses a round robin exercise has been set up to cross check the validity of the SEM-EDX measurements on a VULCANO MCCI sample at CEA, ITU and UJV.

The Thermophysical database will be enlarged to CANDU applications by the distribution of an AECL report on CANDU related physical properties.

Deliverables

Contribution to progress report on CORIUM topic (D107) at 48 months

Milestones and expected result

Technical milestones associated to benchmark exercises are detailed on road map defined by sub-topics leaders.

Fourth period conclusion meeting, assessment of work and definition of future joint R&D at 47 months

Hydrogen Behaviour in Containment (HBC)

Work package number	12		Start date or starting event:							37	
Activity Type	Other specific activities										
Participant id	1	7	13	15	19	20	21	23	30	31	32
Person-months per participant:	6	4.5	4.5	1.5	1.5	9	5.25	1.5	6	3	0
Participant id	33	35	37	43	47	48	49	50	53		
Person-months per participant:	1.5	1.5	0	0	3	0	3.75	2.55	0		

Objectives

This WP concerns two main issues:

- Containment atmosphere mixing and hydrogen distribution in the containment, with respect to risk of high concentration,
- Hydrogen combustion and associated risk mitigation.

A more complete understanding is needed on the following physical processes:

- For containment atmosphere mixing, it is essential to determine with good confidence the hydrogen distribution in the different parts of the containment, taking account of containment geometry (multi-compartment), mass and energy exchanges coming from phenomena as wall condensation, spray and sump evaporation. During the JPA3 period, the following issues were investigated: condensation modelling (compilation of state-of-the-art report on condensation modelling in CFD codes and initiation of Condensation benchmark), modelling of containment sprays (1st part of Spray benchmark, based on TOSQAN and MISTRA experimental results), and simulation of PAR-atmosphere interaction (conclusion of 1st phase of PARIS benchmark). Within JPA4, investigations of these three issues will be pursued. The condensation benchmark results of the 1st phase "Benchmark 0" will be compared, and the 2nd phase "Benchmark 1" will be organized. The revised simulation results of the 1st part of the spray benchmark and the results of the 2nd part will be compared and analysed. The 2nd phase of the PAR-atmosphere interaction benchmark will be organized.
- For hydrogen combustion and associated risk mitigation: formation of combustible gas mixtures in containments, its local gas composition and potential combustion modes. The investigations take into account the containment geometry (multi-compartment), mass and energy exchanges (wall condensation, spray and sump evaporation), local multidimensional effects of hydrogen combustion. For mitigation measures recombiners are studied in detail. In TPA/JPA4 model development for recombiners will continue with the target to come up with a unique integral model for ASTEC. Also, work to couple hydrogen distribution and combustion will continue as well as reactor applications of hydrogen combustion.

The main WP objective will be the progressive integration of the R&D capacities on these issues, in order to better coordinate the research activities and optimise the available competences and resources. This will be done particularly through:

- Joint investigation of the physical processes in order to reach a common understanding through syntheses on experimental programs and on their interpretation, and the organisation of workshops.
- Development of adequate models for the above physical processes to be implemented into ASTEC.

This will lead to the definition and proposal of a joint R&D programme (models, experiments) to solve this issue, either by re-orientation of existing programmes or by launching new ones.

Description of work

Task 12.1. Review and selection of available experiments/models for interpretation and modelling activities. Comparison of models, sensitivity analyses and scaling issues, to be addressed in a numerical benchmark problem. Discussion of experimental activities and recommendations for the specification of experiments/programmes: TOSQAN, MISTRA (OECD and national), ThAI (OECD), ENACCEF and REKO. Transfer of information (experimental data as well as models) on catalytic recombiners to WP-12-2.

Task 12.2. Synthesis of analyses and interpretations of experiments from above Task with existing models or codes (CFD codes, TONUS, COM3D, REACFLOW, ASTEC, COCOSYS....).

Task 12.3. Further work on specific containment related models for CFD (spray, recombiners...) and applicability of CFD to real plants (review of issues related to code performance, meshing, scaling effects...).

Task 12.4. Model synthesis and common proposal of models to be implemented into ASTEC but also recommendations

for implementation of containment-related physical models for CFD codes.

Deliverables

Contribution to progress report on the CONTAINMENT topic (D108) at 48 months.

Contribution to the revision SARNET Integrated R&D Plan at 43 months: D96

Milestones and expected result

Fourth period conclusion meeting, assessment of work and definition of future joint R&D at 43 months

Fast Interactions with Corium (FIC)

Work package number	13		Start date or starting event:					37			
Activity Type	Other specific activities										
Participant id	1	7	15	19	21	23	24	31	32	37	
Person-months per participant:	6	1.5	2.25	0	3	0.45	4.5	9	3.75	0	
Participant id	43										
Person-months per participant:	1.65										

Objectives

The diverse interaction modes of corium, ejected into the reactor cavity after RPV failure, may lead to high temperature and pressure loads on the containment or vital components. Depending on the conditions at failure and on reactor geometry, fuel-coolant-interactions (FCI) or direct containment heating (DCH) can take place.

A more complete understanding is needed on the fluid-dynamic, thermal and chemical processes, for model development and validation, especially for the application to the reactor case that requires a scaling in dimension and from model fluids to corium.

The main WP objective will be the progressive integration of the R&D capacities on these issues, in order to better coordinate the research activities and optimise the available competences and resources. This will be done particularly through:

- Joint investigation of the physical processes in order to reach a common understanding through syntheses on experimental programs and on their interpretation.
- Development of adequate models, for the DCH only, for the above physical processes to be implemented into ASTEC.

This will lead to the definition and proposal of a joint R&D programme (models, experiments) to solve this issue, either by re-orientation of existing programmes or by launching new ones.

Description of work

Task 13.1. Review and selection of available experiments/models for interpretation and modelling activities. Recommendation for further test and recommendation for further interpretation and model development.

Discussion of experimental activities and recommendations for the specification of experiments/programmes for the DCH issue (DISCO facilities) and the FCI issue (exp. facilities: KROTOS/PLINIUS). As for FCI, a close link with the OECD-SERENA programme exists.

Task 13.2. Synthesis of analyses and interpretations of experiments from above Task with existing models or improved models and codes (MC3D, IKEJET/IKEMIX, IDEMO-2D, SIPHRA3D, COMETA for FCI, and CONTAIN, MAAP4, and ASTEC for DCH).

Task 13.3. Assessment of performed work. Model synthesis and common proposal of models to be implemented into ASTEC, as far as possible.

Deliverables

Contribution to progress report on the CONTAINMENT topic (D108) at 48 months.

Contribution to the revision SARNET Integrated R&D Plan at 43 months: D96

Milestones and expected result

Fourth period conclusion meeting, assessment of work and definition of future joint R&D at 43 months

Fission Product Release and Transport (FPRT)

Work package number	14		Start date or starting event:							37			
Activity Type	Other specific activities												
Participant id	1	3	7	15	16	21	23	25	30	36	47	50	53
Person-months per participant:	6	7.5	3.7	3.3	0.8	3.2	0.9	3.0	1.1	3.8	0.8	2.2	1.2

Objectives

The rationales for these issues related to fission product release and transport in the RCS result from the 5th FWP EURSAFE project:

- Quantification of the source term, in particular for Ru, under oxidation conditions / air ingress, covering release in-core and transport in the primary circuit;
- Improvement of predictability of iodine species exiting the RCS to provide a best estimate of the source into the containment, this includes consideration of PWR silver/indium/cadmium control rod release, as Ag, In and Cd species can affect the physical and chemical form of the iodine being transported

The main WP objective is the progressive integration of the R&D capabilities on these issues, in order to coordinate better the research activities and optimise the available competences and resources. This will be done particularly through:

- Joint investigation of the physical processes in order to reach a common understanding through syntheses on experimental programmes and on their interpretation;
- Development of adequate models for the above physical processes to be implemented into ASTEC.

This will lead to the definition and proposal of a joint R&D programme (models, experiments) to solve this issue, either by re-orientation of existing programmes or by launching new ones.

Description of work

Task 14.1. Review and selection of available experiments/models for interpretation and modelling activities.

Discussion of experimental activities and recommendations for specification of the following experiments/programmes: VTT Ru speciation and general revaporisation/speciation tests, Canadian experiments on Ru release, VERDON, MERARG, RUSSET, VERCORS, EMAIC, FZK Zr/air oxidation tests, CHIP, Phébus-FP and QUENCH.

Task 14.2. Synthesis of analyses and interpretations of the above experiments with existing models or codes.

Task 14.3. Synthesis of plant applications to define fuel conditions in-core following air ingress, to help define conditions for the Ru experiments.

Task 14.4. Model synthesis and common proposal of models to be implemented into ASTEC.

Deliverables

Progress report on SOURCE TERM topic (D109) at 48 months.

Milestones and expected result

Fourth period conclusion meeting, assessment of work and definition of future joint R&D at 47 months

AEROSol Behaviour impact on source term (AEROB)

Work package number	15			Start date or starting event:					37						
Activity Type	Other specific activities														
Participant id	1	7	8	10	12	15	17	23	29	30	36	47	50	53	55
Person-months per participant:	0.8	0.7	3.0	6.0	1.5	0.7	1.5	0.4	7.5	0.4	3.0	0.8	0.7	0.8	4.5

Objectives

The rationale for the issues related to aerosol behaviour result from the 5th FWP EURSAFE project:

- Quantification of the source term for aerosol retention in the secondary side of steam generator and leakage through cracks in the containment wall;
- Quantification of the source into the containment due to remobilisation (re-volatilisation and resuspension) in the RCS.

The main WP objective is the progressive integration of the R&D capacities on these issues, in order to better coordinate the research activities and optimise the available competences and resources. This will be done particularly through:

- Joint investigation of the physical processes in order to reach a common understanding through syntheses on experimental programmes and on their interpretation;
- Development of adequate models for the above physical processes to be implemented into ASTEC.

This will lead to the definition and proposal of a joint R&D programme (models, experiments) to solve this issue, either by re-orientation of existing programmes or by launching new ones.

Description of work

Task 15.1. Review and selection of available experiments/models for interpretation and modelling activities. Discussion of experimental activities and recommendations for the specification of following experiments/programmes: ARTIST, PSAERO, HORIZON, PECA/SGTR, RADSOL, STORM resuspension tests, Canadian re-vaporisation tests the JRC re-vaporisation tests REVAP, general revaporisation/speciation tests at VTT and a possible test in COLIMA.

Task 15.2. Synthesis of analysis and interpretations of above experiments with existing models or codes.

Task 15.3. Model synthesis and common proposal of models to be implemented into ASTEC.

Deliverables

Progress report on SOURCE TERM topic (D109) at 48 months.

Milestones and expected result

Fourth period conclusion meeting, assessment of work and definition of future joint R&D at 47 months

CONTainment CHEMistry impact on source term (CONTCHEM)

Work package number	16			Start date or starting event:									37	
Activity Type	Other specific activities													
Participant id	1	2	7	9	10	12	15	19	23	36	43	50	53	
Person-months per participant:	3.8	3	0.7	3	6.0	2.3	1.6	0.4	1.5	5.3	3.0	0.5	1.1	

Objectives

The rationale for the issues related to iodine chemistry in the containment result from the 5th FWP EURSAFE project that drew conclusions on needs for improvement of predicting iodine chemistry in the containment, to reduce the uncertainty in the iodine source term. The effect of fission product release on passive autocatalytic recombiners on the source term, and ruthenium behaviour on the containment are also considered.

The main WP objective is the progressive integration of the R&D capacities on these issues, in order to better coordinate the research activities and optimise the available competences and resources. This will be done particularly through:

- Joint investigation of the physical processes in order to reach a common understanding through syntheses on experimental programmes and on their interpretation;
- Development of adequate models for the above physical processes to be implemented into ASTEC.

This will lead to the definition and proposal of a joint R&D programme (models, experiments) to solve this issue, either by re-orientation of existing programmes or by launching new ones

Description of work

Task 16.1. Review and selection of available experiments/models for interpretation and modelling activities. Discussion of experimental activities and recommendations for the specification of following experiments/programmes: EPICUR, CAIMAN, SISYPHE, Chalmers tests, PARIS, ThAI-Iod9, Phébus-FP, Canadian iodine tests as available, RECI experiments and possible successors, and IRSN tests on ruthenium behaviour in the containment.

Task 16.2. Synthesis of analyses and interpretations of above experiments with existing models or codes.

Task 16.3. Model synthesis and common proposal of models to be implemented into ASTEC.

Deliverables

Progress report on SOURCE TERM topic (D109) at 48 months.

Milestones and expected result

Fourth period conclusion meeting, assessment of work and definition of future joint R&D at 47 months

Education and Training (ET)

Work package number	17	Start date or starting event:							37	
Activity Type	Other specific activities									
Participant id	32									
Person-months per participant:	1.5									

Person-months will be clarified later (around 18 person.months), after identification of teachers in the candidate organisations (only, the topical coordinator (KTH), is identified).

Objectives

Develop Courses on Severe Accident Phenomenology, Modelling and Applications

Develop Courses on Severe Accident Management and PSA2

Description of work

The Education and Training programme in SARNET is focusing on raising the competence level of students and researchers engaged in severe accident activities. Towards this purpose, then approach is to develop courses on the various areas of severe accidents. A course on severe accident phenomenology was given in Cadarache in January 2006. Another course, more targeted at plant personnel of PWRs and BWRs was given in March 2007. Another course entitled "LWR Severe Accident Analysis, Applications and Management Guidelines" will be tentatively scheduled before the end of 2007. This course would be a continuation of the course given in January 2006 and would be organized along with OECD who will describe their progress in severe accidents.

A course, targeted at plant personnel of VVERs and CANDUs is in the planning stage.

Another course on PSA and consequent models is also at a planning stage.

Finally, contacts will be maintained with the ENEN.

Deliverables

Tentatively, two courses could be given during the month 37-54 period.

Milestones and expected result (tentative, without real commitment)

Completion of a first version SA analysis Course at 42 months

Completion of a Course on VVERs and CANDUs at 48 months

Completion of a first version of PSA or SAM Course at 54 months

BOOK on severe accident phenomenology (BOOK)

Work package number	18	Start date or starting event:							37	
Activity Type	Other specific activities									
Participant id	32									
Person-months per participant:	1.5									

Person-months will be clarified later (around 18 person.months), after identification of writers in the candidate organisations (only, the topical coordinator: KTH is considered in this table).

Objectives

To develop a text (source) book on Severe Accident Phenomenology.

Description of work

At present there is no textbook on severe accident phenomenology, which can be used by the students and researchers to learn the subject area. A textbook is quite essential in terms of providing knowledge in a concise and focussed manner along with the references, which could be used by a student or a researcher to perform independent and more detailed studies. The textbook should deal with the whole progression of the severe accident including the initial transient leading to a severe accident caused by additional faults. This textbook, probably, would be quite voluminous due to the large body of material and the large number of papers and studies in Severe Accidents. The text should be reviewed by a set of peer reviewers. The intent should be to provide not only the methodology but also an assessment of the research results. The textbook should be addressed to students and researchers beyond the level of Masters in Nuclear Engineering. An abbreviated version may be addressed to the students, who enrol in the European Masters in Nuclear engineering Programme under ENEN auspices.

In addition to the text book, a book of Lecture Notes on Severe Accident Phenomenology, based on the lectures given in the course delivered in January 2006 will be published in April 2007.

Deliverables

lecture notes of the first course of January 2006 at month 37 (D123)

Book first draft at month 45 (D69)

Book final draft at month 51 (D103)

Milestones and expected results

The final draft of the book will be completed in 2008

MOBility programme (MOB)

Work package number	19	Start date or starting event:							37	
Activity Type	Other specific activities									
Participant id	32									
Person-months per participant:	1.5									

Objectives

To develop the Mobility and Training Programme for students and researchers, to form teams of researchers and to develop training for reactor operators in severe accident domain.

Description of work

At the beginning of SARNET Project, there was no organized programme in Europe under which students and researchers could go to different laboratories for education and training in the severe accident area. One element to develop is the summer internship programme under which a student spends a summer at another University (than his own) to learn about the severe accident work ongoing there.

The second element of this WP is the development of the deputation programme in which a researcher from one laboratory will spend three months to one year at another European Laboratory where he / she participates in an area of the severe accident research ongoing there. In this mobility programme, the long term goal is to build teams which would engage together in a certain activity of the NoE e.g. code debugging, code validation, simulant material experiments, real material experiments, etc.

Deliverables

Final state of SARNET mobilities (D124) at 54 months

Milestones and expected results

Placing of 12 mobilities per year

MANAGement (MANAG)

Work package number	20		Start date or starting event:						37		
Activity Type	Other specific activities										
Participant id	1	7	21	23	30	32	36				
Person-months per participant:	22	4	4	2.5	4	2.5	4				

Objectives

Coordinate the JPA technically and financially

This activity involves mainly the Coordinator and the topical coordinators

Description of work

- Monitor progress of JPA
- Check release of deliverables and survey milestones
- Organize technical reviews when necessary
- Anticipating and examining possible difficulties in JPA execution
- Making synthesis for JPA update (12 months after SARNET beginning) for Governing Board approval
- Elaborate budget for the second JPA (month 13 to month 30)
- Distribute community funds as decided in the Consortium agreement;
- Organize meetings of Governing Board, Advisory Committee and Ad-hoc Scientific Review Committee.
- Establish cost statement for the first year
- Organize information diffusion (newsletter, progress reports, ...)
- Organize periodically a general conference (to be coupled with ASTEC users club meeting), every 18 months

Deliverables

International seminar ERMSAR in June 2007 at month 39: D98

At 42 months:

Mid term progress report (D125)

At 48 months:

Annual progress and management reports (D110, D111)

JPA update proposal, JPA5 (D112)

Milestones and expected result

Second SARNET conference (June 2007)

5.5 List and Status of SARNET Deliverables

List and Status of SARNET Deliverables Joint programme of activities 18 months (months 37 - 54)

(In Italics deliverables produced during the first 36 months of the contract)

Del. no. ²	Deliverable name	WP no.	Lead participant	Estimated indicative person months	Nature ³	Dissemination level ⁴	Delivery date ⁵ (proj. month)
1	<i>SARNET WEB site</i>	1	23	2	O	PU	6
2	<i>Data Base Proposal</i>	6	28	10	R	CO	6
3	<i>ACT specification</i>	1	23	3	R	CO	9
4	<i>Student mobility plan</i>	19	32	1	R	PU	9->23
5	<i>Researcher mobility plan</i>	19	32	1	R	PU	9->23
6	<i>Progress report on ASTEC Activities</i>	2-4	1-23	20	R	CO	12
7	<i>ASTEC WEB site</i>	2	1	3	O	RE	12
8	<i>ASTEC Assess. Matrix</i>	3	1	15	R	RE	12
9	<i>ASTEC Bench. matrix</i>	4	1-23	15	R	RE	12
10	<i>Indicator Assessment.</i>	8	1	4	R	CO	12
11	<i>Progress report on CORIUM Activities</i>	9-11	7	3	R	CO	12
12	<i>CORIUM Exp. Recom</i>	9-11	7	10	R	CO	12
13	<i>CORIUM Interp Synth.</i>	9-11	7	28	R	CR	12
14	<i>CORIUM Model Recom</i>	9-11	7	18	R	CR	12
15	<i>CORIUM Prog. Revision</i>	9-11	7	10	R	CO	12
16	<i>Progress report on CONTAIN. Activities</i>	12,13	21	3	R	CO	12
17	<i>CONTAIN. Exp. Recom</i>	12,13	21	10	R	CO	12
18	<i>CONTAIN. Interp Synth.</i>	12,13	21	28	R	CR	12
19	<i>CONTAIN. Model Recom</i>	12,13	21	18	R	CR	12
20	<i>CONTAIN.Prog. Revision</i>	12,13	21	10	R	CO	12

² Deliverable numbers in order of delivery dates: D1 – Dn

³ Please indicate the nature of the deliverable using one of the following codes:

R = Report; **P** = Prototype; **D** = Demonstrator; **O** = Other

⁴ Please indicate the dissemination level using one of the following codes:

PU = Public

PP = Restricted to other programme participants (including the Commission Services).

RE = Restricted to a group specified by the consortium (including the Commission Services).

CO = Confidential, only for members of the consortium (including the Commission Services).

CR = Confidential, parts of the reports only for members of working on the same subject (including the Commission Services)

⁵ Month in which the deliverables will be available. Month 1 marking the start of the project, and all delivery dates being relative to this start date.

Del. no.²	Deliverable name	WP no.	Lead participant	Estimated indicative person months	Nature³	Dissemination level⁴	Delivery date⁵ (proj. month)
21	<i>Progress Report on Source Term (ST) activities</i>	14-16	1-36	3	R	CO	12
22	<i>ST Exp. Recom</i>	14-16	1-36	10	R	CO	12
23	<i>ST Interp Synth.</i>	14-16	1-36	28	R	CR	12
24	<i>ST Model Recom</i>	14-16	1-36	18	R	CR	12
25	<i>ST Prog. Revision</i>	14-16	1-36	10	R	CO	12
26	<i>Annual progress report</i>	20	1	6	R	CO	12
27	<i>JPA update</i>	20	1	4	R	CO	12
28	<i>Budget Revision</i>	20	1	1	R	CO	12
29	<i>Cost statements</i>	20	1	1	R	CO	12
30	<i>ASTEC Assessment Report</i>	3	1	100	R	CR	15
31	<i>ASTEC Evaluation Report</i>	4	1-23	100	R	CR	15
32	<i>SA Course</i>	17	32	12	R	PU	15-> 25
33	<i>NEPTUNO Particip.</i>	17	32	2	R	PU	15-> >25
34	<i>Requirements for ASTEC V2 dev. plan</i>	2	1-23	12	R	RE	18
35	<i>Specifications of ASTEC adaptation to different NPP and systems</i>	2	1	30	R	CO	18
36	<i>Status Report on PSA2, methodology</i>	5	1	15	R	RE	18
37	<i>Status Report on PSA2, uncertainty assessment</i>	5	1	15	R	RE	18
38	<i>Status Report on PSA2, event tree</i>	5	1	15	R	RE	18
39	<i>Experimental Data Base Catalogue</i>	6	28	21	R	CO	18
40	<i>Revision of EURSAFE Conclusions</i>	7	23	30	R	PU	18->31
41	<i>PSA2 Course</i>	17	32	12	R	PU	18->25
42	<i>Book, skeleton</i>	18	32	12	R	RE	30
43	<i>Synthesis of requests from ACT users</i>	1	1	3	R	PU	18
44	<i>ERMSAR 2005</i>	20 + all	1	10	O	PU	20
45	<i>Revision of Mobility plan</i>	19	32	2	R	PU	21
46	<i>Progress report on ASTEC Activities</i>	2-4	1-23	20	R	CO	24

Del. no. ²	Deliverable name	WP no.	Lead participant	Estimated indicative person months	Nature ³	Dissemination level ⁴	Delivery date ⁵ (proj. month)
47	<i>ASTEC Adaptation to different reactor types (Prog. Rep.)</i>	2	1	15	R	RE	30->36
48	<i>ASTEC New Models</i>	2	1-23	15	R	RE	30->36
49	<i>Indicator Assessment.</i>	8	1	4	R	CO	24
50	<i>Progress report on CORIUM Activities</i>	9-11	7	3	R	CO	24
51	<i>CORIUM Exp. Recom</i>	9-11	7	10	R	CO	24
52	<i>CORIUM Interp Synth.</i>	9-11	7	28	R	CR	24
53	<i>CORIUM Model Recom</i>	9-11	7	18	R	CR	24
54	<i>CORIUM Prog. Revision</i>	9-11	7	10	R	CO	24
55	<i>Progress report on CONTAIN. Activities</i>	12,13	21	3	R	CO	24
56	<i>CONTAIN. Exp. Recom</i>	12,13	21	10	R	CO	24
57	<i>CONTAIN. Interp Synth.</i>	12,13	21	28	R	CR	24
58	<i>CONTAIN. Model Recom</i>	12,13	21	18	R	CR	24
59	<i>CONTAIN.Prog. Revision</i>	12,13	21	10	R	CO	24
60	<i>Progress Report on Source Term (ST) activities</i>	14-16	36	3	R	CO	24
61	<i>ST Exp. Recom</i>	14-16	36	10	R	CO	24
62	<i>ST Interp Synth.</i>	14-16	36	28	R	CR	24
63	<i>ST Model Recom</i>	14-16	36	18	R	CR	24
64	<i>ST Prog. Revision</i>	14-16	36	10	R	CO	24
65	<i>Annual progress report</i>	20	1	6	R	CO	24
66	<i>JPA update</i>	20	1	6	R	CO	24
67	First version of R&D programme	7+all	1	6	R	PU	24->38
68	<i>Update of Mobility Plan</i>	19	32	2	R	RE	25->30
69	Book first draft	18	32	12	R	RE	30->45
70	<i>Probabilistic software comparison for PSA2</i>	5	1	3	R	RE	26
71	<i>Proposals of harmonized methods to assess hydrogen combustion and immediate consequences of vessel breach issues in a level 2 PSA.</i>	5	1	5	R	RE	34

Del. no. ²	Deliverable name	WP no.	Lead participant	Estimated indicative person months	Nature ³	Dissemination level ⁴	Delivery date ⁵ (proj. month)
72	Recommendations of methods to take into account MCCI and iodine releases in a level 2 PSA	5	1	5	R	RE	33->48
73	<i>Status report on dynamic reliability methods application to level 2 PSA</i>	5	1	5	R	RE	34
74	<i>Mid term progress report</i>	20	1	1	R	PU	32
75	<i>Review of existing guidelines</i>	5.1	36	3	R	RE	36
76	<i>Synthesis on ASTEC VI.2 validation</i>	3	1	100	R	RE	35
77	<i>Synthesis on ASTEC VI.2 benchmarking</i>	4	1	100	R	RE	35
78	<i>Course on Severe Accident Progression</i>	17	1	12	O	PU	36
79	Experimental Data Base Catalogue Revision 1	6	28	21	R	CO	36 → 48
80	<i>Progress report on ASTEC Activities</i>	2-4	1-23	20	R	CO	36
81	Indicator Assessment.	8	1	4	R	CO	36
82	Progress report on CORIUM Activities	9-11	7	3	R	CO	36
83	Report on EARLY Activities	9	7	32	R	CR	36
84	Progress report on LATVES Activities	10	7	32	R	CR	36
85	Report on EXCORE Activities	11	7	32	R	CR	36
86	Progress report on CONTAIN. Activities	12,13	21	3	R	CO	36
87	Report on HBC Activities	12	21	35	R	CR	36
88	Report on FIC Activities	13	21	35	R	CR	36
89	Progress Report on Source Term (ST) activities	14-16	36	3	R	CO	36
90	Report on FPRT Activities	14	36	32	R	CR	36
91	Report on AEROB Activities	15	36	32	R	CR	36

Del. no. ²	Deliverable name	WP no.	Lead participant	Estimated indicative person months	Nature ³	Dissemination level ⁴	Delivery date ⁵ (proj. month)
92	Report on CONTCHEM Activities	16	36	32	R	CR	36
93	Annual Management report	20	1	6	R	CO	36
94	Annual Progress report	20	1	6	R	CO	36
95	JPA update N°3 (JPA4)	20	1	6	R	CO	36
96	Finalized version of R&D programme	7	23	12	R	PU	36 → 43
97	Results of the benchmark exercise for application of dynamic reliability methods	5.3	1, 11, 23, 44	12	R	RE	36
98	ERMSAR 2007	20 + all	1	10	O	PU	39
99	Definitions of "large early releases " and of "reactor safe states"	5.1	1	10	R	RE	42
100	Recommendations of methods to take into account physical phenomena	5.1 & 5.2	1	12	R	RE	42
101	Review of software for uncertainty and sensitivity methods	5.2	7	5	R	RE	42
102	Status report on SDTPD method development	5.3	11, 44	24	R	RE	42
103	Book final draft	18	32	12	R	CO	42-> 51
104	PSA and consequences Course	17	32	12	O	PU	34-> 54
105	Progress report on ASTEC Activities	2-4	1-23	20	R	CO	48
106	Indicator Assessment.	8	1	4	R	CO	48
107	Progress report on CORIUM Activities	9-11	7	3	R	CO	48
108	Progress report on CONTAINMENT Activities	12,13	21	3	R	CO	48
109	Progress Report on Source Term Activities	14-16	36	3	R	CO	48
110	Annual Management report	20	1	6	R	CO	48
111	SARNET Annual Progress report	20	1	6	R	CO	48
112	JPA update N°4 (JPA5)	20	1	6	R	CO	48

Del. no.²	Deliverable name	WP no.	Lead participant	Estimated indicative person months	Nature³	Dissemination level⁴	Delivery date⁵ (proj. month)
113	Final synthesis of ASTEC developments by partners	2	1	30	R	RE	54
114	Final synthesis of ASTEC V1 validation by partners	3	1	100	R	RE	54
115	Final synthesis of ASTEC V1 evaluation on plant applications	4	1	100	R	RE	54
116	Harmonized methods for level 1 level 2 PSA interface	5.1, 5.2	39	10	R	RE	48
117	Expert judgment use in level 2 PSA	5.1	30	6	R	RE	48
118	Final report on harmonization of methods	5.1, 5.2	1	12	R	RE	54
119	ASTEC requirements for level 2 PSA use	5.1, 5.2	49	6	R	RE	54
120	Benchmark exercise conclusions	5.3	1	12	R	RE	54
121	Conclusions on SDTPD method development	5.3	11, 48	18	R	RE	54
122	SA analysis and SAM course or Course on VVERs and CANDUs	17	32 or 1	12	O	PU	42 or 48
123	Book of Lecture Notes	18	32	12	R	PU	37
124	Final state of SARNET mobilities	19	32	1	R	PU	54
125	Mid term progress report	20	1	1	R	PU	42

6 Project resources and estimation of incurred eligible costs

6.1 Efforts for the full duration of the project (as defined at the beginning of the project)

Net work Effort Form 1⁶ – Indicative efforts for full duration of project

Project Number (acronym) - 509065 (SARNET)

Figures followed by a * concern the organisations responsible for coordination of Topics in SARNET (during the duration of the project, these responsibilities may change, and this will modify the efforts provided by concerned organisations).

Network Activity Type	Joint Programme of Activities ⁷			Management activities	TOTAL per PARTICIPANT
	Integrating Activities ⁸	Jointly executed research activities ³	Spreading of Excellence activities ³		
1. IRSN *	158	36	8	72	274
2. AEAT		12			12
3. AEKI	12	12			24
4. ARCS	12				12
5. AVN	8				8
6. BUTE	48				48
7. CEA *	78	48	8	12	146
8. CESI		12			12
9. Chalmers		12			12
10. CIEMAT	24	12			36
11. CSN	24				24
12. DEMOKRITOS		2	8		10
13. UPI	48	12			60
14. EA	20				20
15. EDF	24	36			60
16. ENEA	48	24			72
17. FORTUM	12	4			16

⁶ Indicate effort in person months

⁷ 'other specific activities' according to Article II.25 of Annex II to the contract

⁸ except management of the consortium activities

18. FRA ANP SAS	10				10
19. FRA ANP-Gmbh	8	24			32
20. FZJ		12			12
21. FZK *	72	36	8	12	128
22. FZR		12	4		16
23. GRS *	102	36	8	4	150
24. IUSTT-IKE	52	24	8		84
25. INR	54	12	4		70
26. INRNE	48				48
27. IVS	36				36
28. JRC-ISPRA *	12				12
29. JRC-ITU		24			24
30. JRC-PETTEN	54	24			78
31. JSI	24	12			36
32. KTH *	65	24	12	8	109
33. LEI	54	12	8		74
34. NNC	8				8
35. NRG	12	8			20
36. PSI	6	24	4		34
37. RUB		24	8		32
38.					
39. SWEDPOWER	12				12
40. TA		12			12
41. THERMODATA	3	12			15
42. TE	16				16
43. TUS	54	24	8		86
44. ULB	12				12
45. UCL		12			12

46. UJD	28				28
47. UJV	30	24			54
48. UPM		24			24
49. VEIKI	48	12			60
50. VTT	8	24			32
51. VUJE	50				50
52. BTech		24			24
TOTAL per ACTIVITY Type	1404	692	96	108	
Overall TOTAL efforts					2294

WARNING: This table has been established with the assumption that during the duration of the contract there is no changing in organizations (*) responsible of coordinating domains or managing databases or information systems.

6.2 Efforts for the full duration of the project (as defined after 36 months of operation of the project)

Net work Effort Form 1⁹ – Indicative efforts for full duration of project

Project Number (acronym) - 509065 (SARNET)

Figures followed by a * concern the organisations responsible for coordination of Topics in SARNET (during the duration of the project, these responsibilities may change, and this will modify the efforts provided by concerned organisations).

<i>Network Activity Type</i>	Joint Programme of Activities			Management activities	TOTAL per PARTICIPANT
	Integrating Activities	Jointly executed research activities ³	Spreading of Excellence activities ³		
1. IRSN *	131,6	86,42	5,7	70,8	294,52
2. AEAT (WMT)	0	9,68	0	0	9,68
3. AEKI	12	17,5	0	0	29,5
4. ARCS	10	1	0	0	11
5. AVN	6,15	0	0	0	6,15
6. BUTE	40	0	0	0	40
7. CEA *	66,73	65,86	2,7	11,8	147,09
8. CESI (CESI RICERCA)	6	11,5	0	0	17,5
9. Chalmers	0	7	0	0	7
10. CIEMAT	36,3	31,3	0	0	67,6
11. CSN	11,1	0	0	0,3	11,4
12. DEMOKRITOS	0	8,3	1,25	0	9,55
13. UPI	25	13,5	0	0	38,5
14. EA	14,6	0	0	0	14,6
15. EDF	16,9	33,85	0,7	0,3	51,75
16. ENEA	54	22,3	0	0	76,3

⁹ Indicate effort in person months

17. FORTUM	11,44	2,98	0	0	14,42
18. FRA ANP SAS	10,9	0	0	0	10,9
19. FRA ANP-Gmbh	8,4	21,33	0	0	29,73
20. FZJ	0	20,15	0	0	20,15
21. FZK *	38,85	56,4	0	13,3	108,55
22. FZR	0	13,5	0	0	13,5
23. GRS *	101,85	27,67	2,18	9,14	140,84
24. IUSTT-IKE	66,7	33,88	0	0	100,58
25. INR	64,4	15,8	0	0	80,2
26. INRNE	55,3	15	0	0	70,3
27. IVS	48,9	10,5	0	0	59,4
28. JRC-ISPRA *	12	0	0	0	12
29. JRC-ITU	0	30	0	0	30
30. JRC-PETTEN	60,87	28,75	0	4	93,62
31. JSI	20,5	26	0	0	46,5
32. KTH *	62,28	25,05	13	8,8	109,13
33. LEI	63,1	6,5	0	0	69,6
34. NNC	7,5	0	0,9	0	8,4
35. NRG	12,7	4,6	0	0	17,3
36. PSI	14	37,2	0	11,8	63
37. RUB	5,25	20,61	0	0	25,86
38.					
39. SWEDPOWER	7,7	0	0	0	7,7
40. TA	0	0	0	0	0
41. THERMODATA	0	11	0	0	11
42. TE	13,57	0	0	0	13,57

43. TUS	57,5	22,75	1	0,3	81,55
44. ULB	11,1	0	0	0	11,1
45. UCL	0	2,3	0	0	2,3
46. UJD	34,9	0	0	0	34,9
47. UJV	27,7	27,9	0	0	55,6
48. UPM	25	21,5	0	0	46,5
49. VEIKI	61	11,75	0	0	72,75
50. VTT	9,3	19,66	0	0	28,96
51. VUJE	56,6	0	0	0	56,6
52. BTech	0	5,49	0	0	5,49
53. AECL (years 3 and 4)	5,5	7,8	0	0	13,3
54. BNRA (years 3 and 4)	10	0	0	0	10
55. UNEW (years 3 and 4)	0	7,5	0	0	7,5
TOTAL per ACTIVITY Type	1415,19	841,78	27,43	130,54	2414,94
Overall TOTAL efforts					2414,94

Globally, after three years of operation of the project, taking into account three new partners for the last two years on one hand, a lesser involvement of some partners on the other hand and anticipating a 6-month extension of the project (still to be negotiated with the EC) the total effort foreseen today on the project comes to 2415 person months (for a 54-month duration), to be compared to an initial estimate of 2294 person months (for a 48-month duration).

This figure which is 5% above the initial estimate will be reduced and should come back to the initial one for two reasons:

- Today, the figures taken into account for the SARNET year 3 are based on initial JPA3 estimates and when the cost statements are received, the global involvement for year 3 will be reduced as we know that some partners provided less than initially expected. This will be reported in a revision of the present document.
- Probably the same effect will happen with JPA4 figures.

Finally, if needed, it will be quite possible to voluntarily reduce the involvement of partners during the expected contract extension.

6.3 Efforts for the fourth JPA 18-month period (month 37 - month 54)

Network Effort Form 2 – 18-month period, month 37-54

Project Number (acronym) - 509065 (SARNET)

	Participant 1 IRSN	Participant 2 WMTL	Participant 3 AEKI	Participant 4 ARCS	Participant 5 AVN	Participant 6 BUTE	TOTAL ACTIVITIES
Joint Programme of Activities							
Integrating activities	45,00	0,00	3,00	2,50	2,00	16,00	68,50
ACT							0,00
USTIA	13,50			1,00		1,00	15,50
PHYMA	9,00			1,50		3,50	14,00
RAB	9,00					11,50	20,50
PSA2	7,00				2,00		9,00
IED	3,00		3,00				6,00
SARP	3,00						3,00
IA	0,50						0,50
Jointly executed research activities	34,60	3,00	7,50	0,00	0,00	0,00	45,10
CORIUM	12,00						12,00
CONTAINMENT	12,00						12,00
SOURCE TERM	10,60	3,00	7,50				21,10
Spreading of Excellence activities	0,00	0,00	0,00	0,00	0,00	0,00	0,00
ET**							0,00
BOOK**							0,00
MOB							0,00
TOTAL JPA	79,60	3,00	10,50	2,50	2,00	16,00	113,60
Management Activities	22,00	0,00	0,00	0,00	0,00	0,00	22,00
MANAG	22						22,00
TOTAL Management	22,00	0,00	0,00	0,00	0,00	0,00	22,00
TOTAL per PARTICIPANT	101,60	3,00	10,50	2,50	2,00	16,00	
Overall TOTAL EFFORTS							135,60

** a provision of 18 person.months for each one of these 2 topics has been reserved; the contributing partners will be defined later

Network Effort Form 2 - 18 months period, month 37-54

Project Number (acronym) – 509065 (SARNET)

	Participant 7 CEA	Participant 8 CESI RICERCA	Participant 9 Chalmers	Participant 10 CIEMAT	Participant 11 CSN	Participant 12 DEMOKRITOS	TOTAL ACTIVITIES
Joint Programme of Activities							
Integrating activities	25,50	6,00	0,00	12,00	4,00	0,00	116,00
ACT							0,00
USTIA	12,00			1,00			28,50
PHYMA	4,00			8,00			26,00
RAB							20,50
PSA2	3,00				4,00		16,00
IED	3,00	6,00		3,00			18,00
SARP	3,00						6,00
IA	0,50						1,00
Jointly executed research activities	18,90	3,00	3,00	12,00	0,00	3,80	85,80
CORIUM	7,80						19,80
CONTAINMENT	6,00						18,00
SOURCE TERM	5,10	3,00	3,00	12,00		3,80	48,00
Spreading of Excellence activities	0,00	0,00	0,00	0,00	0,00	0,00	0,00
ET**							0,00
BOOK**							0,00
MOB							0,00
TOTAL JPA	44,40	9,00	3,00	24,00	4,00	3,80	201,80
Management Activities	4,00	0,00	0,00	0,00	0,00	0,00	26,00
MANAG	4,00						26,00
TOTAL Management	4,00	0,00	0,00	0,00	0,00	0,00	26,00
TOTAL per PARTICIPANT	48,40	9,00	3,00	24,00	4,00	3,80	
Overall TOTAL EFFORTS							227,80

** a provision of 18 person.months for each one of these 2 topics has been reserved; the contributing partners will be defined later

Network Effort Form 2 - 18 months period, month 37-54

Project Number (acronym) - 509065 (SARNET)

	Participant 13 UPI (Pisa Univers.)	Participant 14 EA	Participant 15 EDF	Participant 16 ENEA	Participant 17 FORTUM	Participant 18 FRA ANP SAS	TOTAL ACTIVITIES
Joint Programme of Activities							
Integrating activities	1,00	5,00	8,70	18,00	3,00	3,70	155,40
ACT							0,00
USTIA	1,00	1,00	1,00	1,00		1,00	33,50
PHYMA				9,00			35,00
RAB		4,00	2,70	8,00		2,70	37,90
PSA2			2,00				18,00
IED					3,00		21,00
SARP			3,00				9,00
IA							1,00
Jointly executed research activities	4,50	0,00	13,85	5,30	1,50	0,00	110,95
CORIUM			4,50	4,50			28,80
CONTAINMENT	4,50		3,75				26,25
SOURCE TERM			5,60	0,80	1,50		55,90
Spreading of Excellence activities	0,00	0,00	0,00	0,00	0,00	0,00	0,00
ET**							0,00
BOOK**							0,00
MOB							0,00
TOTAL JPA	5,50	5,00	22,55	23,30	4,50	3,70	266,35
Management Activities	0,00	0,00	0,00	0,00	0,00	0,00	26,00
MANAG							26,00
TOTAL Management	0,00	0,00	0,00	0,00	0,00	0,00	26,00
TOTAL per PARTICIPANT	5,50	5,00	22,55	23,30	4,50	3,70	
Overall TOTAL EFFORTS							292,35

** a provision of 18 person.months for each one of these 2 topics has been reserved; the contributing partners will be defined later

Network Effort Form 2- 18 months period, month 37-54

Project Number (acronym) - 509065 (SARNET)

	Participant 19 FRA ANP- GmbH	Participant 20 FZJ	Participant 21 FZK	Participant 22 FZR	Participant 23 GRS	Participant 24 IUSTT-IKE	TOTAL ACTIVITIES
Joint Programme of Activities							
Integrating activities	3,00	0,00	15,50	0,00	35,50	25,00	234,40
ACT					3,00		3,00
USTIA			1,00		9,00	15,00	58,50
PHYMA			8,00		4,50	6,00	53,50
RAB					8,00	4,00	49,90
PSA2	3,00				3,00		24,00
IED			3,00		3,00		27,00
SARP			3,00		4,50		16,50
IA			0,50		0,50		2,00
Jointly executed research activities	6,40	9,00	22,10	4,50	9,10	13,88	175,93
CORIUM	4,50		10,65	4,50	4,35	9,38	62,18
CONTAINMENT	1,50	9,00	8,25		1,95	4,50	51,45
SOURCE TERM	0,40		3,20		2,80		62,30
Spreading of Excellence activities	0,00	0,00	0,00	0,00	0,00	0,00	0,00
ET**							0,00
BOOK**							0,00
MOB							0,00
TOTAL JPA	9,40	9,00	37,60	4,50	44,60	38,88	410,33
Management Activities	0,00	0,00	4,00	0,00	2,50	0,00	32,50
MANAG			4,00		2,50		32,50
TOTAL Management	0,00	0,00	4,00	0,00	2,50	0,00	32,50
TOTAL per PARTICIPANT	9,40	9,00	41,60	4,50	47,10	38,88	
Overall TOTAL EFFORTS							442,83

** a provision of 18 person.months for each one of these 2 topics has been reserved; the contributing partners will be defined later

Network Effort Form 2 - 18 months period, month 37-54

Project Number (acronym) - 509065 (SARNET)

	Participant 25 INR	Participant 26 INRNE	Participant 27 IVS	Participant 28 JRC ISPRA	Participant 29 JRC ITU	Participant 30 JRC PETTEN	TOTAL ACTIVITIES
Joint Programme of Activities							
Integrating activities	21,00	18,00	18,00	3,00	0,00	19,50	313,90
ACT							3,00
USTIA	8,00	1,00	1,00			1,00	69,50
PHYMA	2,00	5,00	7,00			15,00	82,50
RAB	8,00	12,00	10,00				79,90
PSA2	3,00					3,00	30,00
IED				3,00			30,00
SARP							16,50
IA						0,50	2,50
Jointly executed research activities	5,40	6,00	4,50	0,00	12,00	7,50	211,33
CORIUM	2,40	6,00	4,50		4,50		79,58
CONTAINMENT						6,00	57,45
SOURCE TERM	3,00				7,50	1,50	74,30
Spreading of Excellence activities	0,00	0,00	0,00	0,00	0,00	0,00	0,00
ET**							0,00
BOOK**							0,00
MOB							0,00
TOTAL JPA	26,40	24,00	22,50	3,00	12,00	27,00	525,23
Management Activities	0,00	0,00	0,00	0,00	0,00	4,00	36,50
MANAG						4,00	36,50
TOTAL Management	0,00	0,00	0,00	0,00	0,00	4,00	36,50
TOTAL per PARTICIPANT	26,40	24,00	22,50	3,00	12,00	31,00	
Overall TOTAL EFFORTS							561,73

** a provision of 18 person.months for each one of these 2 topics has been reserved; the contributing partners will be defined later

Network Effort Form 2 - 18 months period, month 37-54

Project Number (acronym) - 509065 (SARNET)

	Participant 31 JSI	Participant 32 KTH	Participant 33 LEI	Participant 34 NNC	Participant 35 NRG	Participant 36 PSI	TOTAL ACTIVITIES
Joint Programme of Activities							
Integrating activities	6,00	24,50	21,00	3,00	3,70	5,50	377,60
ACT							3,00
USTIA	1,00	12,00	5,00		1,00	2,00	90,50
PHYMA	5,00		2,00				89,50
RAB		6,00	11,00		2,70		99,60
PSA2			3,00	3,00		3,00	39,00
IED		3,00					33,00
SARP		3,00					19,50
IA		0,50				0,50	3,50
Jointly executed research activities	12,00	11,25	1,50	0,00	1,50	16,60	254,18
CORIUM		7,50				4,50	91,58
CONTAINMENT	12,00	3,75	1,50		1,50		76,20
SOURCE TERM						12,10	86,40
Spreading of Excellence activities	0,00	4,50	0,00	0,00	0,00	0,00	4,50
ET**		1,50					1,50
BOOK**		1,50					1,50
MOB		1,50					1,50
TOTAL JPA	18,00	40,25	22,50	3,00	5,20	22,10	636,28
Management Activities	0,00	2,50	0,00	0,00	0,00	4,00	43,00
MANAG		2,50				4,00	43,00
TOTAL Management	0,00	2,50	0,00	0,00	0,00	4,00	43,00
TOTAL per PARTICIPANT	18,00	42,75	22,50	3,00	5,20	26,10	
Overall TOTAL EFFORTS							679,28

** a provision of 18 person.months for each one of these 2 topics has been reserved; the contributing partners will be defined later

Network Effort Form 2 - 18 months period, month 37-54

Project Number (acronym) - 509065 (SARNET)

	Participant 37 RUB	Participant 38	Participant 39 SWEDPOWE R	Participant 40 TECHNICATO ME	Participant 41 THERMODAT A	Participant 42 TRACTEBEL	TOTAL ACTIVITIES
Joint Programme of Activities							
Integrating activities	1,00	0,00	3,00	0,00	0,00	4,00	385,60
ACT							3,00
USTIA	1,00					1,00	92,50
PHYMA							89,50
RAB						3,00	102,60
PSA2			3,00				42,00
IED							33,00
SARP							19,50
IA							3,50
Jointly executed research activities	4,50	0,00	0,00	0,00	4,00	0,00	262,68
CORIUM	4,50				4,00		100,08
CONTAINMENT							76,20
SOURCE TERM							86,40
Spreading of Excellence activities	0,00	0,00	0,00	0,00	0,00	0,00	4,50
ET**							1,50
BOOK**							1,50
MOB							1,50
TOTAL JPA	5,50	0,00	3,00	0,00	4,00	4,00	652,78
Management Activities	0,00	0,00	0,00	0,00	0,00	0,00	43,00
MANAG							43,00
TOTAL Management	0,00	0,00	0,00	0,00	0,00	0,00	43,00
TOTAL per PARTICIPANT	5,50	0,00	3,00	0,00	4,00	4,00	
Overall TOTAL EFFORTS							695,78

** a provision of 18 person.months for each one of these 2 topics has been reserved; the contributing partners will be defined later

Network Effort Form 2 - 18 months period, month 37-54

Project Number (acronym) - 509065 (SARNET)

	Participant 43 TUS	Participant 44 ULB	Participant 55 UNEW	Participant 46 UJD	Participant 47 UJV	Participant 48 UPM	TOTAL ACTIVITIES
Joint Programme of Activities							
Integrating activities	19,00	4,00	0,00	12,00	9,50	13,00	443,10
ACT							3,00
USTIA	1,00			1,00	1,00		95,50
PHYMA	6,00				3,00		98,50
RAB	7,00			11,00	1,50		122,10
PSA2	2,00	4,00			4,00	13,00	65,00
IED							33,00
SARP	3,00						22,50
IA							3,50
Jointly executed research activities	4,65	0,00	4,50	0,00	10,60	4,50	286,93
CORIUM					6,00	4,50	110,58
CONTAINMENT	1,65				3,00		80,85
SOURCE TERM	3,00		4,50		1,60		95,50
Spreading of Excellence activities	0,00	0,00	0,00	0,00	0,00	0,00	4,50
ET**							1,50
BOOK**							1,50
MOB							1,50
TOTAL JPA	23,65	4,00	4,50	12,00	20,10	17,50	734,53
Management Activities	0,00	0,00	0,00	0,00	0,00	0,00	43,00
MANAG							43,00
TOTAL Management	0,00	0,00	0,00	0,00	0,00	0,00	43,00
TOTAL per PARTICIPANT	23,65	4,00	4,50	12,00	20,10	17,50	
Overall TOTAL EFFORTS							777,53

** a provision of 18 person.months for each one of these 2 topics has been reserved; the contributing partners will be defined later

Network Effort Form 2 - 18 months period, month 37-54

Project Number (acronym) - 509065 (SARNET)

	Participant 49 VEIKI	Participant 50 VTT	Participant 51 VUJE	Participant 52 BTech	Participant 53 AECL	Participant 54 BNRA	TOTAL ACTIVITIES
Joint Programme of Activities							
Integrating activities	23,00	5,00	18,00	0,00	3,50	6,00	498,60
ACT							3,00
USTIA	1,00		1,00		1,00	1,00	99,50
PHYMA					1,50	1,00	101,00
RAB	17,00		17,00		1,00	4,00	161,10
PSA2	5,00						70,00
IED		3,00					36,00
SARP		2,00					24,50
IA							3,50
Jointly executed research activities	3,75	9,25	0,00	0,00	4,80	0,00	304,73
CORIUM		3,30			1,50		115,38
CONTAINMENT	3,75	2,55					87,15
SOURCE TERM		3,40			3,30		102,20
Spreading of Excellence activities	0,00	0,00	0,00	0,00	0,00	0,00	4,50
ET**							1,50
BOOK**							1,50
MOB							1,50
TOTAL JPA	26,75	14,25	18,00	0,00	8,30	6,00	807,83
Management Activities	0,00	0,00	0,00	0,00	0,00	0,00	43,00
MANAG							43,00
TOTAL Management	0,00	0,00	0,00	0,00	0,00	0,00	43,00
TOTAL per PARTICIPANT	26,75	14,25	18,00	0,00	8,30	6,00	
Overall TOTAL EFFORTS							850,83

** a provision of 18 person.months for each one of these 2 topics has been reserved; the contributing partners will be defined later

WARNING:

**PARTICIPANT 55 (UNEW) HAS BEEN INSERTED BETWEEN PARTICIPANT 44 AND 46.
PARTICIPANT 45 (UCL) HAS NO ACTIVITY SINCE JPA3.
THERE IS NO PARTICIPANT 38.**

6.4 Estimated breakdown of the requested EC Contribution per reporting period

This part is a copy of the A3.1 form of the contract preparation form. No change has been made since the initial version. So the requested funds for the next period (month 37 to month 48) still amount to 1,570,000 €. Then, some money should remain and, depending on negotiation to be conducted with the European Commission, we could imagine an extension of the contract, for about 6 months, at constant budget. Such a possibility should allow to make a good link before a potential new contract before going really toward a complete self-sustainability of the Network.

Contract Preparation Forms			
 EUROPEAN COMMISSION 6th Framework Programme on Research, Technological Development and Demonstration		Network of Excellence	
			A3.1
Proposal Number	509065	Proposal Acronym	SARNET
Estimated breakdown of the requested EC contribution per reporting period			
Reporting Periods	Month x - month y	Requested Grant to the Budget	
		Total	in which first six months
Reporting Period 1	M1 - M12	1 570 000,00	,00
Reporting Period 2	M13 - M24	1 570 000,00	785 000,00
Reporting Period 3	M25 - M36	1 570 000,00	785 000,00
Reporting Period 4	M37 - M48	1 570 000,00	785 000,00
Reporting Period 5	M49 - M60	,00	,00
Reporting Period 6	M61 - M72	,00	,00
Reporting Period 7	M73 - M84	,00	,00
Total	Full duration	6 280 000,00	2 355 000,00
Estimated costs of the Joint Programme of Activities			
Estimated costs for the full duration		24 352 520,00	
Estimated costs for the first 18 months		9 376 353,00	

6.5 Project management level, description of resources and grant

The following two tables give an estimate of the total resources needed to carry out the Joint Programme of Activities, respectively for the JPA4 18 month-period (April 2007 to September 2008) and for the total duration of the contract (48 months plus expected 6 month extension).

For the JPA4 (18 months)

3 kinds of expenses are considered:

- manpower. It has been evaluated to a lump value of the person-year cost (130000 €/year), whatever the SARNET partner.
- travels for mission, with an average cost of 750€/per mission.
- other expenses related to:
 - o support of ASTEC users, one part of this activity will required a subcontract of 1person.year/year (130000€)

- a sub contract for maintenance and specific development for the ACT, including the improvement of ASTEC web site (provision of 40000€)
- the organisation of a SA modelling course and a SAM/ PSA2 course (50000€)
- mobility; it has been evaluated to 60000 €/year

The total expenses will be around 10.7 M€.

For the total duration of the contract

The evaluation is that made at the beginning of the contract, with the following assumptions:

- no significant changes (/JPA1) in the investigated domains, and in the number of organisations participating to each one;
- 1 person.year/year for the coordinator;
- 2 person.year/year for support, training of users and model implementation in ASTEC (1 of the 2 person.year is provided via a sub contract);
- 1.5 person.year/year for the coordination of scientific and excellence spreading activities;
- 0.25 person.year/year for the management (and user-training) of the experimental data base;
- 0.25 person.year/year for the management of the information system (ACT);
- 0.66 person.year/year / participant to ASTEC activities;
- 0.25 person.year/year / participant to each one of the following activities: Corium, Containment, Source Term,
- 0.15 person.year/year / participant for Research priorities
- 0.15 person.year/year / participant to level2 PSA activities;
- 0.15 person.year/year / participant to excellence spreading activities

We kept the same assumption as above for ACT possible sub-contract.

We assumed the holding of 2 SARNET conferences.

The total expenses will be around 24M€.

JPA FULL COST FOR THE THIRD 18 MONTHS PERIOD (JPA4)

Activities	Nb of organisations	Nb of correspondents per organisation	Nb of meetings within 18 months	Meeting cost	Nb of men-months	Manpower cost	Other costs	Total
ACT development				0		0	40000	40000
Electronic network administration	1	1	2	1500	5	54166,6667		55667
ASTEC user support	2				18	195000	195000	390000
ASTEC WPs	30	1	3	67500	337,7	3658416,667		3725916,667
Level 2 PSA	17	1	3	38250	69	747500		785750
Exp. Data Base Administration	1	1	1	750	4,5	48750		49500
Exp. Data Feeding	9	1		0	39,5	427916,6667		427916,6667
Research priorities	8	2	2	24000	24,5	265416,6667		289417
Integration Monitoring	7			0	0	0		0
Corium WPs	23	2	3	103500	121,5	1316250		1419750
Containment WPs	20	2	3	90000	91,65	992875		1082875
Source Term WPs	23	2	3	103500	103,5	1121250		1224750
Education & training	12	1	2	18000	43,5	471250	50000	539250
Mobility programme	10	1	0	0	0,75	8125	90000	98125
Management team	7	1,5	3	23625	42	455000		478625
Governing board meetings	49	0,66	2	48510				48510
Advisory committees meetings	10	1	2	15000				15000
SARNET CONFERENCES (1)							50000	50000
Total				534135	901,1	9761917	425000	10721052

Lump cost of one man-month (€) 10833
 Lump cost of one participation /meeting € 750

SARNET JPA COST (€)	10721051,67
----------------------------	--------------------

JPA FULL COST FOR THE WHOLE CONTRACT DURATION

103 / 104

Activities	Nb of organisations	Nb of correspondents per organisation	Nb of meetings per year	Meeting cost	Nb of men-years/year	Manpower cost	Other costs	Total
ACT development				0		0	50000	50000
Electronic network administration	1	1	1	3000	0,25	125000		128000
ASTEC user support	2				1	500000	500000	1000000
ASTEC WPs	28	1	2	168000	18,98	9490000		9658000
Level 2 PSA	17	1	2	102000	2,55	1275000		1377000
Exp. Data Base Administration	1	1	1	3000	0,25	125000		128000
Exp. Data Feeding	5	1		0	1,25	625000		625000
Research priorities	8	2	1	48000	1,2	600000		648000
Integration Monitoring	7			0	0	0		0
Corium WPs	18	2	2	216000	4,75	2375000		2591000
Containment WPs	19	2	2	228000	5	2500000		2728000
Source Term WPs	21	2	2	252000	5,5	2750000		3002000
Education & training	12	1	1	36000	1,45	725000		761000
Mobility programme	10	1			0,5	62500	60000	122500
Management team	7	1	2	42000	2,5	1250000		1292000
Governing board meetings	49	0,66	1	97020				97020
Advisory committees meetings	10	1	1,5	45000				45000
SARNET CONFERENCES (2)							100000	100000
Total				1240020	45,18	22402500	610000	24352520

Lump cost of one man-year (€) 125000
 Lump cost of one participation /meeting € 750

SARNET JPA COST (€)	24352520
----------------------------	-----------------

Appendix A- Consortium description, new contractors

A.1 Update of the list of partner organizations and of scientists involved in the network

Three new candidates entered the Consortium since the beginning of the third JPA:

- Atomic Energy of Canada Limited (AECL: participant N°53)
- The Bulgarian Nuclear Safety Authority (BNRA: participant N°54)
- and the Newcastle University (NCU: participant N°55).

The participant N°45 stopped his participation to SARNET activities but has not been formally withdrawn from the Consortium.

A.2 Sub-contracting

The activity consisting in supporting ASTEC users will be sub-contracted. The reason is that experts in ASTEC will be mostly involved in tasks aiming at improving and assessing the code.

The company that which is contractually in charge of supporting ASTEC users (maintenance and Web site) will carry the corresponding activity. After a call for tenders in 2001, a contract has been initiated in December 2001 and lasted up to December 2004. In order to support the SARNET ASTEC users, an amendment of this sub-contract was decided to extend the duration of 1 year, thus covering the whole year 2005.

Thus, the contract was finished in December 2005. During the year 2005, a call for tenders has been set up for the following 3 years, and the sub-contractor selection was done end of 2005.

IRSN is responsible for the subcontracting, the amount of the sub-contract is around 130 k€/year.

The development and maintenance of ACT and of the public SARNET Web site require a subcontract. GRS is responsible for the subcontracting, the amount of the sub-contract for the whole duration of the project is around 120k€, subject to some extensions to increase its user-friendliness.

The training for using STRESA tools (necessary for data implementation) may punctually require the support of external organisations. JRC-ISPRA or trainee organisation will be responsible for these subcontracts.

A.3 Third parties

The participation of AEA-T (now WMT) to SARNET will be co-funded by BRITISH ENERGY, and by BNFL (in-kind contribution in Joint Executed Research Activities).

The participation of VTT to SARNET will be co-funded by the State Nuclear Waste Management Fund (VYR), the Nordic Nuclear Research Programme (NKS) and Finnish Nuclear Safety and Radiation Authority (STUK).

The participation of GRS to SARNET will be financially supported by the German Federal Ministry of Economy and Labour.